

XVME-979

Mass Storage Module

Revision	Description	Date
A	Manual Released	3/01
B	Addition of CD-ROM switch settings	4/01
C	Addition of Functional Revs	4/01

Xycom Automation Part Number 740979(C)

Trademark Information

Brand or product names are registered trademarks of their respective owners. Windows is a registered trademark of Microsoft Corp. in the United States and other countries.

Copyright Information

This document is copyrighted by Xycom Incorporated (Xycom) and shall not be reproduced or copied without expressed written authorization from Xycom. The information contained within this document is subject to change without notice.

For European Users: WARNING

This is a Class A product. In a domestic environment this product may cause radio interference in which case the user may be required to take adequate measures.

INSTALLATION: Electromagnetic Compatibility WARNING

The connection of non-shielded equipment interface cables to this equipment will invalidate FCC EMI and European Union EMC compliance and may result in electromagnetic interference and/or susceptibility levels that are in violation of regulations which apply to the legal operation of this device. It is the responsibility of the system integrator and/or user to apply the following directions that relate to installation and configuration:

1. All interface cables must include shielded cables. Braid/foil type shields are recommended. Communication cable connectors must be metal, ideally zinc die-cast backshell types, and provide 360 degree protection about the interface wires. The cable shield braid must be terminated directly to the metal connector shell, ground drain wires alone are not adequate.
2. For systems other than Pentium II logic board (AHIP6+): In those cases where an external mouse is used, the snap-on ferrite bead provided (P/N 116046) must be installed on the mouse cable at the host end in order to comply with relevant EMI regulations.
3. Protective measures for power and interface cables as described within this manual must be applied. Do not leave cables connected to unused interfaces or disconnected at one end. Changes or modifications to this device not expressly approved by the manufacturer could void the user's authority to operate the equipment.
4. EMC compliance is, in part, a function of PCB design. Third party add-on AT/XT peripheral PCB assemblies installed within this apparatus may void EMC compliance. FCC/CE compliant PCB assemblies should always be used where possible. XYCOM AUTOMATION can accept no responsibility for the EMC performance of this apparatus after system integrator/user installation of PCB assemblies not manufactured and/or expressly tested and approved for compliance by XYCOM AUTOMATION. It is the responsibility of the system integrator/user to ensure that installation and operation of such devices does not void EMC compliance.

CHAPTER ONE - INTRODUCTION	7
Interconnect Definition	8
Module Features.....	8
Hardware Specifications	9
Environmental Specifications.....	10
CHAPTER 2 – INSTALLATION	11
Installing into a VMEbus Card Cage.....	11
XVME-977 purchased before May 13, 2001, Functional Rev 1.2.....	12
XVME-977 purchased after May 13, 2001, Functional Rev 1.3.....	12
P5 - External Floppy Drive Connector.....	16
Configuring the XVME-979	17
XVME-979 Switches	18
SL CD-ROM Adapter Switch Settings.....	18
VMEbus Interface	19
P1 Connector.....	19
P2 Connector.....	20
P3 CD-ROM Connector.....	21
P4 Hard Drive Connector.....	22
P5 Floppy Drive Connector Front Panel.....	22

Chapter One - Introduction

The XVME-979 Mass Storage Module provides an easy way to integrate both hard drive and CD-ROM drive into a VMEbus system. The module is a single-slot VME form factor disk drive available with a 5.25 inch CD-ROM drive and an external floppy connector (XVME-979/1), or with a CD-ROM drive, external 2.5-inch hard drive, and external floppy connector (XVME-979/2).

Compact and easy to install, the XVME-979 Mass Storage Module is an ideal solution for a variety of VMEbus systems. This module is built to communicate with Xycom's XVME-65x and 66x VMEbus PC/AT processors.

Power for the XVME-979 is provided by the P1 and P2 connectors. Signals are routed through P2. Figure 1-1 illustrates this in a block diagram of the XVME-979.

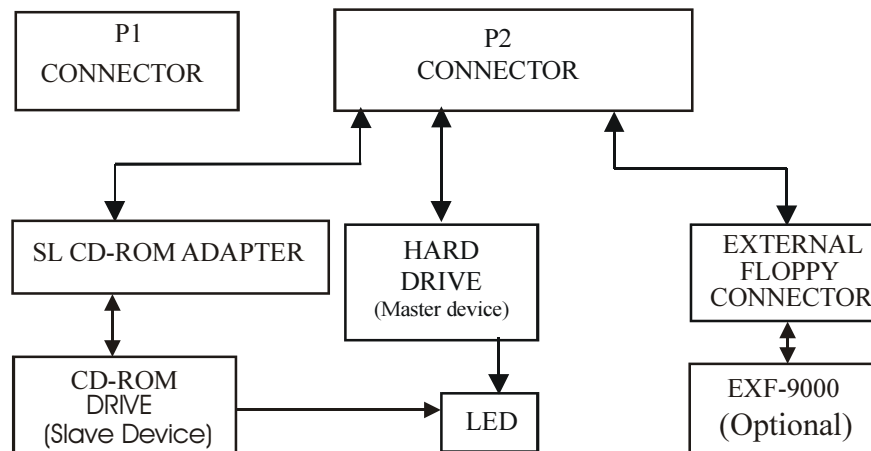

Figure 1-1. XVME-979 Block Diagram

Interconnect Definition

Signals from the CPU board to the XVME-979 travel via the P2 connector. The floppy drive connector is a 26-pin board mount connector that is accessible through the front panel. The hard drive plugs directly into a 50-pin right angle 2mm connector. The CD-ROM drive will be connected to a SL CDROM Interface Adapter Board. The Adapter Board will plug directly into a 50-pin .8mm connector. The CD-ROM Drive will be accessible through the front panel.

Figure 2 shows the connector and switch placement diagram.

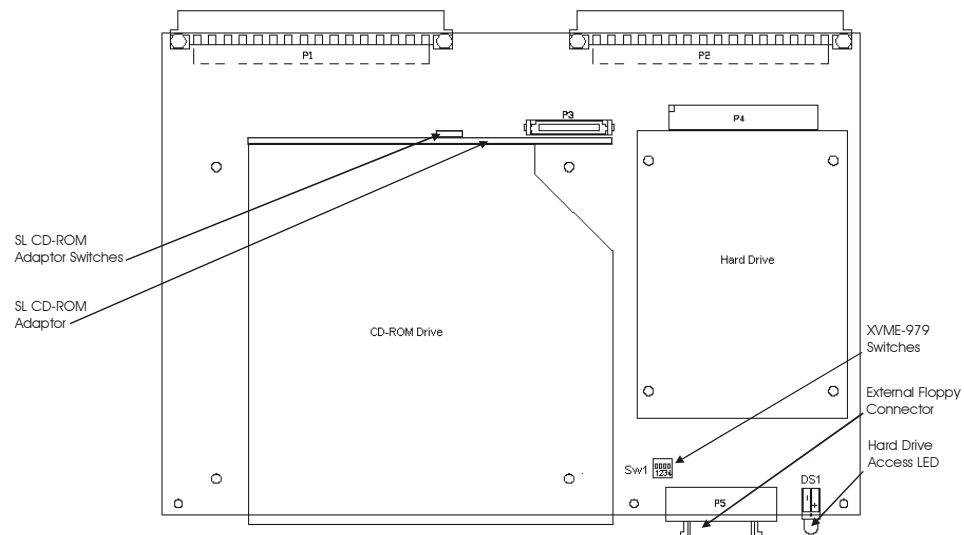

Figure 2. XVME-979 Connector and Switch Placement Diagram

Module Features

The XVME-979 Mass Storage Module offers the following features:

- Occupies one VMEbus slot
- CD-ROM drive (XVME-979/1 and /2)
- Drive activity LED
- Needs only +5V
- IDE hard drive (XVME-979/2 only)
- Front panel connector for an optional external, 3 1/2" 1.44Mbyte floppy drive (9000-EXF) (XVME-979/2 only)

Hardware Specifications

CD-ROM Drive

Table 1-1 provides the hardware specifications for the CD-ROM Drive.

Table 1-1 CD-ROM Drive Hardware Specifications

Characteristic	Specification
Interface	ATAPI/IDE
Type	5.25 inch
Speed	X24

Hard Drive

Table 1-2 provides the hardware specifications for the hard drive.

Table 1-2 Hard Drive Hardware Specifications

Characteristic	Specification
Interface	IDE
Type	2.5 inch

Floppy Drive

Table 1-3 provides the hardware specifications for the floppy drive.

Table 1-3 Floppy Drive Hardware Specifications

Characteristic	Specification
Interface	PC/AT-compatible
Compatibility	3.5", 1.44 Mbyte

Environmental Specifications

Table 1-4 provides the environmental specifications for the XVME-979.

Table 1-4 Environmental Specifications

Characteristic	Specification
Humidity	20 to 80% RH, non-condensing
Temperature	
Operating	5° to 50° C Ambient (41° to 122° F)
Non-operating	-40° to 65° C ambient (-0° to 149° F) transportation/packaged
Altitude	
Operating	-200 ft. to 10,000 ft.
Non-operating	-200 ft. to 40,000 ft.
Vibration	
Operating	0.2 g, 5 to 500 Hz
Non-operating	2 g, 5 to 500 Hz
Shock	
Operating	5 g peak or less (half sine wave 11 msec) duration
Non-operating	50 g peak or less (half sine wave 11 msec) duration

Chapter 2 – Installation

This chapter describes how to install the XVME-979 Mass Storage Module into the VMEbus backplane. It also provides information on connecting the XVME-979 to Xycom's XVME-65x and XVME-660 VMEbus PC/AT processor modules.

Installing into a VMEbus Card Cage

The XVME-979 occupies only one double-high VMEbus slot, and fits into any standard 6U VMEbus card cage. Like all of Xycom's modules, the XVME-979 is designed to comply with all electrical VMEbus backplane specifications. This module only draws current from the +5 volt power supply.

Caution

Never attempt to install or remove any boards before turning off power to the bus and all related external power supplies.

Before installing a module, determine and verify all connections to external devices or power supplies.

Technical Note

It should not be necessary to use excessive force or pressure to engage the connectors. If the board does not connect properly with the backplane, remove the module and inspect all connectors and guide slots for possible damage or obstructions.

The XVME-979/1 is a CD-ROM only version. To complement your system, use the XVME-977, which comes with a three-connector 64-pin ribbon cable to distribute the IDE and floppy drive signals.

XVME-977 purchased before May 13, 2001, Functional Rev 1.2

Using the XVME-977 (purchased prior to May 13, 2001) with the XVME-979/1

There are two ways to accomplish this:

1. Remove the four hard disk drive mounting screws from the back of the XVME-977 and remove the hard disk drive. Connect the hard disk drive to the XVME-979/1 and install the hard disk drive mounting screws (that were removed from the XVME-977) to the back of the XVME-979/1.

or

2. A product modification to the XVME-977 can be made. Call Xycom Technical Assistance for details at 1-800-289-9266.

NOTE: The floppy drive on the XVME-977 can be used and there would be no need for a 9000-EXF (External Floppy Disk Drive). The 9000-EXF and the floppy disk drive on the XVME-977 can not be used together.

XVME-977 purchased after May 13, 2001, Functional Rev 1.3

XVME-977 products purchased after May 13, 2001 have received the modifications necessary for the 977 to work properly with XVME-979/1 products.

The XVME-979/2 is a CD-ROM, hard drive, and floppy drive version and requires the use of a two-connector 64-pin ribbon cable. The XVME-977 can not be used with an XVME-979/2

Figure 2-1 depicts installation of the XVME-979 board.

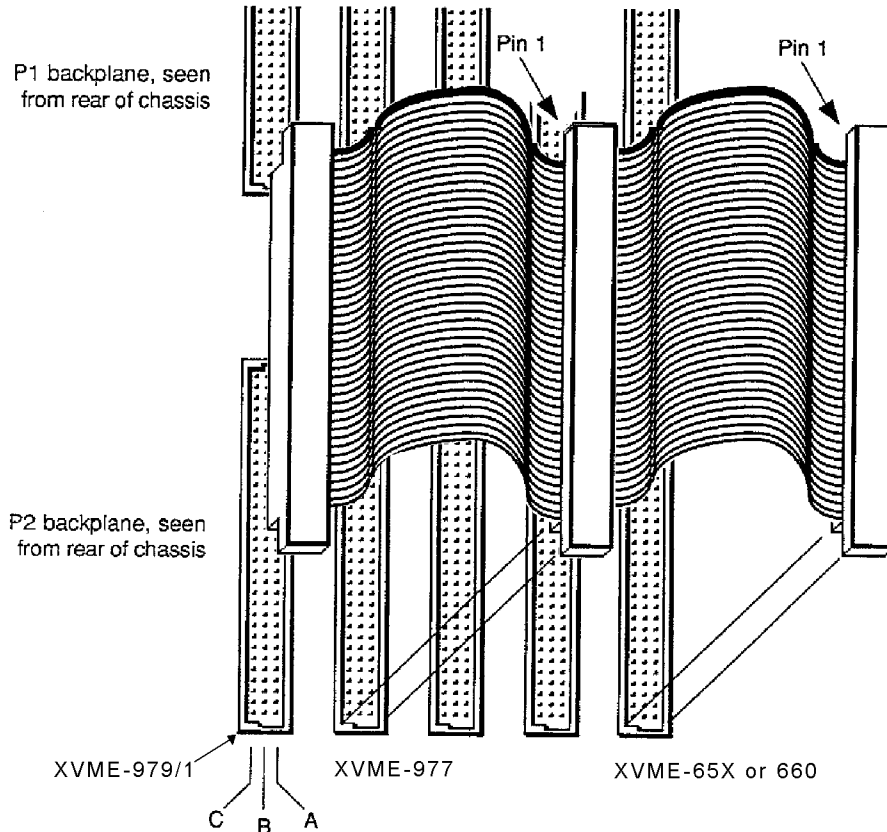

Figure 2-1. XVME-979/1 Installation (CD-ROM version only)

To install the XVME-979/1 in a card cage:

1. Turn off power to the chassis.
2. Connect the jumper cable from the CPU slot to the XVME-977 slot on the rear of the P2 backplane, and then to the 979/1 slot as shown in Figure 2-1. This will bring the EIDE and floppy signals from the CPU board to the XVME-977 (hard drive/floppy drive) and the 979/1 (CD-ROM drive). The hard drive is the “master” and the CD-ROM drive is the “slave”.

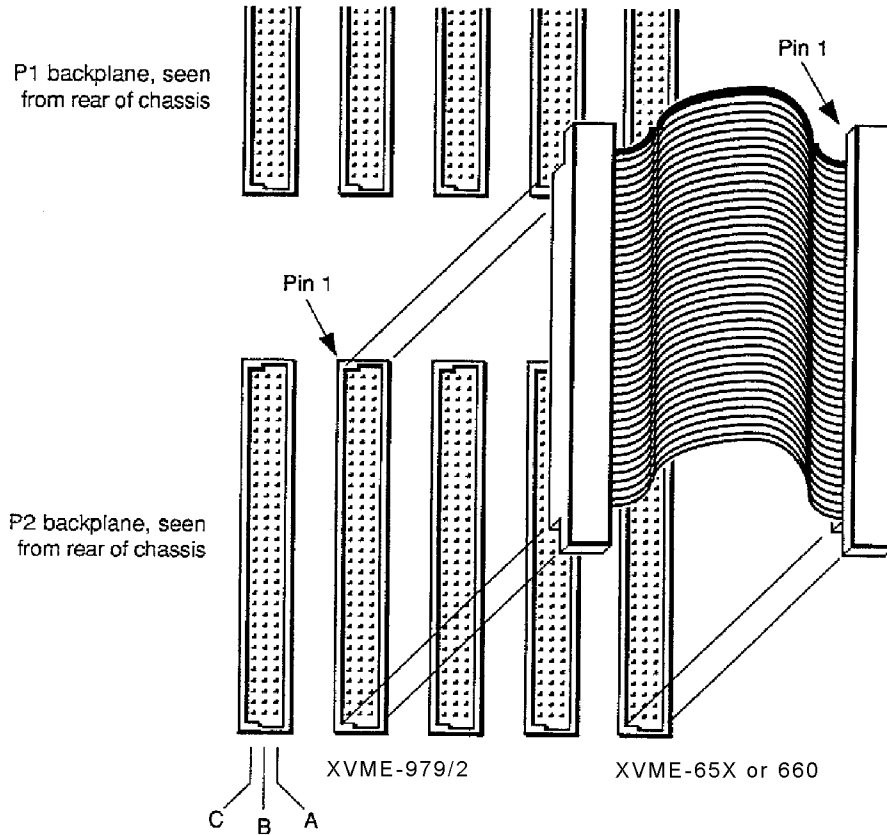

Figure 2-2. Installation (CD-ROM version only)

To install the XVME-979/2 in a card cage:

1. Turn off power to the chassis.
2. Connect the jumper cable from the CPU slot to the XVME-979 slot on the rear of the P2 backplane, as shown in Figure 2-1. This will bring the EIDE and floppy signals over from the CPU board to the XVME-979/2. The hard drive is the “master” and the CD-ROM drive is the “slave”.
3. Apply straightforward pressure to the handles on the front of the panel, until the connectors are fully engaged and properly seated.
3. Once the board is properly seated, secure it to the chassis by tightening the machine screws at the top and bottom of the XVME-979 board.
4. Turn on power to the unit.

Note

To avoid corruption, do not attach the external floppy drive with a diskette installed.

There are four screw holes on the external floppy disk drive (9000-EXF) for mounting the drive to a panel.

Note

Make sure the floppy drive cable is able to reach the external floppy connector on the system before mounting.

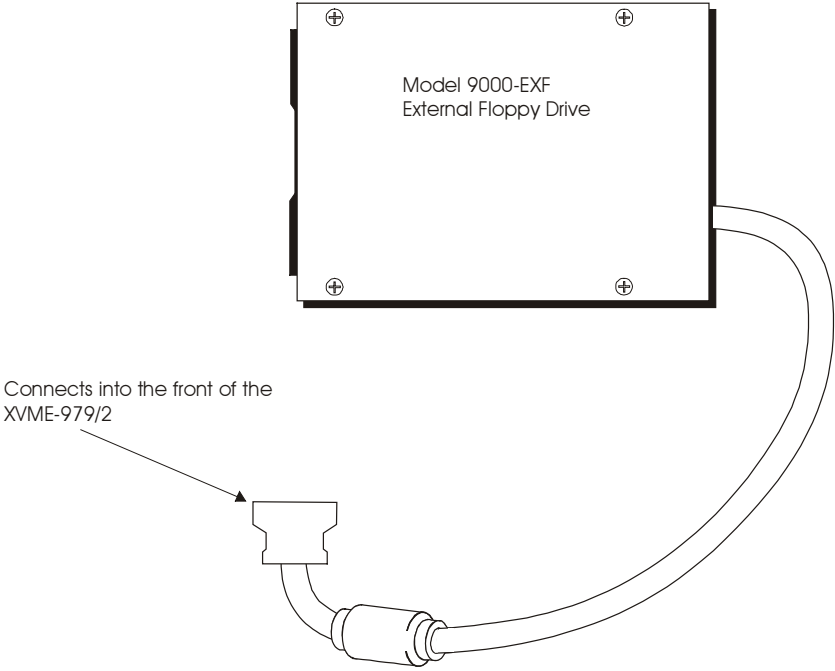

P5 - External Floppy Drive Connector

The 26-pin connector on the front of the 979/2 allows you to connect an external floppy.

Pin	Signal	Pin	Signal
1	+5V	14	FSTEP*
2	IDX*	15	NC
3	FDS1*	16	FWD*
4	+5V	17	GND*
5	NC	18	FWE*
6	DCHG*	19	GND
7	NC	20	FTK0*
8	NC	21	GND
9	GND	22	FWP*
10	MO1*	23	GND
11	NC	24	FRDD*
12	FDIRC*	25	GND
13	NC	26	FHS*

*The XVME-979 allows the 9000-EXF to be plugged in or unplugged under power. Be sure to remove the diskette before plugging in or unplugging the unit.

Configuring the XVME-979

To set floppy and hard drive specifications:

1. Turn on power to the unit.
2. Press F2 to enter the Main Setup menu.
3. Using the arrow keys, move down the screen to the Diskette A: option and set it as follows:

Diskette A: [1.44 MB, 3½"]

Diskette B: [Not Installed]

4. Move to the IDE Adapter 0 Master option, and press ENTER to display the IDE Adapter Sub-menu.
5. Press ENTER to auto-configure the hard drive, or type in specific parameters. Use the information printed on the label affixed to the hard drive. An example of the label information is shown below:

FIXED DISK:0 TYPE: USER CY920 HD10 ST17 LZ920 WP0

6. Press ESC after all changes have been made.
7. Once the specifications have been set, reboot the system. The operating system can now be loaded. The hard drive is preformatted with a 1:1 interleave, so low-level formatting is not required.

Installation and configuration of the XVME-979 is now complete.

NOTE

CD-ROM Legacy Support is supported in the XVME-660 BIOS, therefore the XVME-660 BIOS will recognize the XVME-979 CD-ROM and allow you to boot from the CD-ROM. The appropriate device driver will need to be loaded for general operation.

CD-ROM Legacy Support is not supported in the XVME-65x BIOS. Therefore, during the boot sequence, if you have installed an XVME 65x product along with the XVME-979, the 65x BIOS will not recognize the CD-ROM. Wait until the computer boots into the operating system and install the correct operating system device driver, which will allow you to access the CD-ROM.

XVME-979 Switches

The following table lists the XVME-979 switches, their default positions, and their functions (refer to figure 2, *Connector and Switch Placement Diagram* for the location of the switches). SW-1 and SW-2 provide hard drive configuration as defined by the drive manufacturer.

The following switches are used in the XVME-979. The default is in **bold print**.

<i>SW-1</i>	<i>SW-2</i>	<i>Function description</i>
OFF	OFF	Drive is master; slave may be detected using DASP signal – CSEL is ignored
OFF	ON	Use CSEL pin grounding to differentiate master from slave
ON	OFF	Drive is slave (a master drive should be present also). CSEL is ignored
ON	ON	Not used

<i>SW-3</i>	<i>Function description</i>
NC	Not used
<i>SW-4</i>	<i>Function description</i>
ON	Orb ground is connected to signal ground (associated with P5)
OFF	Independent orb ground (associated with P5)

SL CD-ROM Adapter Switch Settings

The default settings are in **bold print**.

SW1-1	SW1-2	SW1-3	SW1-4	CD-ROM
ON	OFF	ON	OFF	MASTER
ON	ON	OFF	OFF	SLAVE

VMEbus Interface

The VMEbus connector provides power (+5 V and GND). The bus in and bus out are connected together, and the IACKIN* and IACKOUT* are connected together.

P1 Connector

Pin	A	B	C
1	NC	NC	NC
2	NC	NC	NC
3	NC	NC	NC
4	NC	BG0IN*	NC
5	NC	BG0OUT*	NC
6	NC	BG1IN*	NC
7	NC	BG1OUT*	NC
8	NC	BG2IN*	NC
9	GND	BG2OUT*	GND
10	NC	BG3IN*	NC
11	GND	BG3OUT*	NC
12	NC	NC	NC
13	NC	NC	NC
14	NC	NC	NC
15	GND	NC	NC
16	NC	NC	NC
17	GND	NC	NC
18	NC	NC	NC
19	GND	NC	NC
20	NC	GND	NC
21	IACKIN*	NC	NC
22	IACKOUT*	NC	NC
23	NC	GND	NC
24	NC	NC	NC
25	NC	NC	NC
26	NC	NC	NC
27	NC	NC	NC
28	NC	NC	NC
29	NC	NC	NC
30	NC	NC	NC
31	NC	NC	NC
32	+5V	+5V	+5V

P2 Connector

Pin	A	B	C
1	+5V	+5V	HDRESET*
2	+5V	GND	HD0
3	+5V	NC	HD1
4	NC	NC	HD2
5	NC	NC	HD3
6	NC	NC	HD4
7	NC	NC	HD5
8	NC	NC	HD6
9	NC	NC	HD7
10	NC	NC	HD8
11	NC	NC	HD9
12	NC	GND	HD10
13	NC	+5V	HD11
14	NC	NC	HD12
15	NC	NC	HD13
16	NC	NC	HD14
17	NC	NC	HD15
18	PDIAG	NC	GND
19	GND	NC	DIOW*
20	NC	NC	DIOR*
21	IDX*	NC	IORDY
22	MO1*	GND	CABLE_SEL
23	DMARQ*	NC	INTRQ (IRQ 14)
24	FDS1*	NC	IOCS16*
25	DMACK*	NC	DA0
26	FDIRC*	NC	DA1
27	FSTEP*	NC	DA2
28	FWD*	NC	CS1*
29	FWE*	NC	CS3*
30	FTK0*	NC	DASP*
31	FWP*	GND	FHS*
32	FRDD*	+5V	DCHG*

P3 CD-ROM Connector

Pin	Name	Pin	Name
1	NC	26	GND
2	NC	27	IORDY
3	GND	28	DMACK*
4	GND	29	INTRQ (IRQ 14)
5	RESETDRV*	30	IOCS16*
6	DD8	31	DA1
7	DD7	32	PDIAG
8	DD9	33	DA0
9	DD6	34	DA2
10	DD10	35	CS1*
11	DD5	36	CS3*
12	DD11	37	DASP*
13	DD4	38	+5V
14	DD12	39	+5V
15	DD3	40	+5V
16	DD13	41	+5V
17	DD2	42	+5V
18	DD14	43	GND
19	DD1	44	GND
20	DD15	45	GND
21	DD0	46	GND
22	DMARQ*	47	CABLE_SEL
23	GND	48	GND
24	DIOR*	49	NC
25	DIOW*	50	NC

P4 Hard Drive Connector

Pin	Signal	Pin	Signal
1	SW1 pin 8	26	NC
2	SW1 pin 1	27	DMRQ*
3	SW1 pin 7	28	GND
4	SW1 pin 2	29	DIOW*
5	NC	30	GND
6	NC	31	DIOR*
7	RESETDR	32	GND
8	GND	33	IORDY
9	DD7	34	CABLE SEL
10	DD8	35	DMACK*
11	DD6	36	GND
12	DD9	37	INTRQ (IRQ 14)
13	DD5	38	IOCS16*
14	DD10	39	DA1
15	DD4	40	PDIAG
16	DD11	41	DA0
17	DD3	42	DA2
18	DD12	43	CS1
19	DD2	44	CS3*
20	DD13	45	DASP*
21	DD1	46	GND
22	DD14	47	+5V
23	DD0	48	+5V
24	DD15	49	GND
25	GND	50	NC

P5 Floppy Drive Connector Front Panel

Pin	Name	Pin	Name
1	+5V	14	FSTEP*
2	IDX*	15	NC
3	FDS1*1	16	FWD*
4	+5V	17	GND
5	NC	18	FEW*
6	DCHG*	19	GND
7	NC	20	FTK0*
8	NC	21	GND
9	GND	22	FWP*
10	MO1*	23	GND
11	NC	24	FRDD*
12	FDIRC*	25	GND
13	NC	26	FHS*

INDEX

card cage installation	11
Configuring the XVME-979	17
connectors	
floppy drive	22
hard drive	22
P119	
P220	
environmental specifications	10
Environmental Specifications	10
features, module	8
floppy drive	
connector	22
hardware specifications	9
specifications, setting	17
hard drive	
connector	22
hardware specifications	9
specifications, setting	17
Hardware Specifications	9
installation, card cage	11
interface, VMEbus	19
module features	8
P1 connector	19
P2 connector	20
specifications	
environmental	10
hardware	
floppy drive	9
hard drive	9
VMEbus interface	19
XVME-979 Switches	18

740979(C)

Xycom Automation, Inc.

734-429-4971 • Fax: 734-429-1010

<http://www.xycom.com>

Canada Sales: 905-607-3400

Northern Europe Sales: +44-1604-790-767

Southern Europe Sales: +39-011-770-53-11

XYCOM[™]
AUTOMATION
Open the Possibilities[®]