

XVME-653/658

Single-Slot VMEbus
Intel Pentium[®]/AMD-K6[®]-2
Processor Module

User Manual

Revision	Description	Date
A	Manual Released	2/98
B	Revision	6/99
C	Corrected byte-swapping information	9/03
D	Updated memory manufacturer's list	3/04

Part Number 740653 (D)

Trademark Information

Brand or product names are trademarks or registered trademarks of their respective owners. Pentium is a registered trademark and MMX is a trademark of Intel Corporation. Windows and Windows NT are registered trademarks of Microsoft Corp. in the US and in other countries.

Copyright Information

This document is copyrighted by Xycom Automation, Incorporated (Xycom Automation) and shall not be reproduced or copied without expressed written authorization from Xycom Automation.

The information contained within this document is subject to change without notice. Xycom Automation does not guarantee the accuracy of the information.

WARNING – For European Users:

This is a Class A product. In a domestic environment this product may cause radio interference, in which case the user may be required to take adequate measures.

INSTALLATION – Electromagnetic Compatibility WARNING

European Union Directive 89/336/EEC requires that this apparatus comply with relevant ITE EMC standards. EMC compliance demands that this apparatus is installed within a VME enclosure designed to contain electromagnetic radiation and which will provide protection for the apparatus with regard to electromagnetic immunity. This enclosure must be fully shielded. An example of such an enclosure is a Schroff 7U EMC-RFI VME System chassis, which includes a front cover to complete the enclosure.

The connection of non-shielded equipment interface cables to this equipment will invalidate European Free Trade Area (EFTA) EMC compliance and may result in electromagnetic interference and/or susceptibility levels that are in violation of regulations which apply to the legal operation of this device. It is the responsibility of the system integrator and/or user to apply the following directions, as well as those in the user manual, which relate to installation and configuration:

All interface cables should be shielded, both inside and outside of the VME enclosure. Braid/foil type shields are recommended for serial, parallel, and SCSI interface cables. Whereas external mouse cables are not generally shielded, an internal mouse interface cable must either be shielded or looped (1 turn) through a ferrite bead at the enclosure point of exit (bulkhead connector). External cable connectors must be metal with metal backshells and provide 360-degree protection about the interface wires. The cable shield must be terminated directly to the metal connector shell; shield ground drain wires alone are not adequate. VME panel mount connectors that provide interface to external cables (e.g., RS-232, SCSI, keyboard, mouse, etc.) must have metal housings and provide direct connection to the metal VME chassis. Connector ground drain wires are not adequate.

Table of Contents

Chapter 1 – Introduction	1
Module Features	1
Architecture	2
CPU Chip.....	2
Ethernet Controller	2
PCI Local Bus Interface.....	2
Video Controller	2
Fast IDE controller and Floppy Drive Controller	2
VMEbus Interface.....	3
Card Expansion Options	3
Onboard Memory.....	3
DRAM Memory	3
Secondary Cache.....	4
Flash BIOS	4
ROM Site	4
Nonvolatile SRAM.....	4
DiskOnChip.....	4
Universal Serial Bus Port.....	4
Serial and Parallel Ports.....	4
Mouse Port.....	4
Keyboard Interface	5
Hard and Floppy Drives.....	5
Watchdog Timer	5
Operational Description	6
Environmental Specifications	7
Hardware Specifications	8
System Configuration and Expansion Options Tables.....	9
Chapter 2 – Installation	10
Jumper Settings	12
CPU Configuration	12
CPU Core Voltage	12
CPU Voltage Plane Configuration.....	12
Processor Speed	13
Memory.....	13
Switch Settings.....	13
Registers	14
Register 218h – Abort/Clear CMOS Port.....	14
Register 219h – LED/BIOS Port	15
Register 233h – Watchdog Timer Port	15
Register 234h – NVRAM and DiskOnChip Port.....	16
Connectors.....	17
Serial Port Connectors	17
Parallel Port Connector.....	17

USB Port Connector	18
VGA Connector	18
Keyboard Port Connector	18
Auxiliary Connector	19
VMEbus Connectors.....	20
P1 Connector	20
P2 Connector	21
Interboard Connector 1 (P4)	22
Interboard Connector 2 (P3)	23
Installing the XVME-653/658 into a Backplane.....	24
Enabling the PCI Ethernet Controller	27
Loading the Ethernet Driver	27
Pinouts for the RJ-45 10/100 BaseT Connector	27
Using a DiskOnChip.....	27
Chapter 3 – BIOS Setup Menus.....	29
Getting to the BIOS Setup Menus	29
Moving through the Menu	29
BIOS Main Setup Menu	30
IDE Adapter 0 Master and Slave Submenus	32
Memory Cache Submenu.....	34
Memory Shadow Submenu.....	35
Boot Sequence Submenu	36
Numlock Submenu.....	37
Advanced Menu	38
Integrated Peripherals Submenu	39
32-Pin ROM Site Submenu	40
Advanced Chipset Control Submenu.....	41
Security Menu	42
VMEbus Setup Menu	44
System Controller Submenu	45
Master Interface Submenu	46
Slave Interface Submenus.....	47
Exit Menu	48
BIOS Compatibility.....	49
Chapter 4 – Programming	50
Memory Map.....	50
I/O Map	51
IRQ Map.....	52
VME Interface.....	52
System Resources	53
VMEbus Master Interface.....	53
VMEbus Slave Interface.....	54
VMEbus Interrupt Handling.....	55
VMEbus Interrupt Generation	55
VMEbus Reset Options	55
PCI BIOS Functions	56
Calling Conventions	56

16-Bit Interface	56
32-Bit Interface	56
PCI BIOS Function Calls.....	57
Locating the Universe Chip	58
Read Configuration Byte.....	59
Read Configuration Word.....	59
Read Configuration Dword.....	60
Write Configuration Byte.....	60
Write Configuration Word.....	61
Write Configuration Dword.....	61
Software-Selectable Byte-Swapping Hardware	62
Byte-Ordering Schemes	62
Numeric Consistency.....	64
Address Consistency.....	65
Chapter 5 – XVME-973/1 Drive Adapter Module.....	66
Connectors.....	67
P1 Connector	67
P2 Connector	68
P3 Connector	70
P4 Connector	71
P5 Connector	72
Appendix A – DRAM SIMM Installation.....	73
Appendix B – Drawings	76
Index	ix

Chapter 1 – Introduction

The XVME-653 VMEbus Pentium® MMX™ PC-compatible VMEbus processor module and the XVME-658 VMEbus AMD-K6®-2 PC-compatible VMEbus processor module are designed to combine the high performance and ruggedized packaging of the VMEbus with the broad application software base of the IBM PC standard. These modules integrate the latest processor and chipset technology.

At the core of the XVME-653 is an Intel® 233 MHz Pentium CPU with MMX technology. This generation of Pentium processors features enhanced multimedia instructions, larger level 1 caches, and a 10 to 20 percent performance increase over standard Pentium processors.

At the core of the XVME-658 is an AMD 333 MHz K6-2 CPU with 3DNOW!™ Technology. 3DNOW!™ Technology is the first innovation to the x86 processor architecture that significantly enhances floating-point-intensive three-dimensional (3D) graphics performance. The AMD-K6-2 system can provide performance comparable to the many of the Pentium II systems on the market today.

Module Features

The XVME-653 and the XVME-658 offer the following features:

- 233 MHz Intel Pentium MMX CPU (XVME-653)
- 333 MHz AMD-K6-2 CPU with 3DNOW! Technology (XVME-658)
- Up to 256 MB fast-page or EDO DRAM in 72-pin SIMM sites, with ECC or parity
- 512 KB of synchronous level 2 pipeline cache
- High-performance PCI local bus SVGA controller with 2 MB of VRAM
- PCI Enhanced IDE controller with DMA
- 10/100 Mbit PCI Ethernet controller with front RJ-45 connector
- 32-pin site for *DiskOnChip* or battery-backed SRAM
- PCI-to-VMEbus interface with DMA
- Two high-speed 16550-compatible serial ports
- One Universal Serial Bus (USB) port
- EPP or ECP configurable parallel port
- PS/2-style keyboard and mouse ports
- Configurable hardware byte-swapping logic (XVME-658 and XVME-653/31x)
- Expansion options for PC/104, PMC, ISA, and PCI cards

Architecture

This section describes the XVME-653/658 processor modules' architecture.

CPU Chip

The XVME-653 supports the Intel 233 MHz Pentium MMX processor. The MMX processor features new instructions to improve multimedia performance. A dynamic branch prediction unit, improved internal pipelines, and separate 16 KB data and instruction caches further enhance performance.

The XVME-658 supports the AMD 333 MHz K6-2 processor with 3DNOW! Technology. The AMD 333 MHz K6-2 processor incorporates the MMX instruction set as well as the new 3DNOW! Technology instruction set, which can increase the speed of floating-point-intensive operations and 3D graphics. In addition, a 64 KB L1 cache, four x86 instructions decoders, a large branch prediction table, and six integer-execution units further enhance performance.

Ethernet Controller

The XVME-653/658 contains a state-of-the-art Intel 82558 10/100 BaseTX Ethernet controller with a 32-bit PCI bus-mastering interface to support 100 Mbits per second bus transfers. The RJ-45 connector on the module's front panel provides autosensing for 10BaseT and 100BaseTX connections.

PCI Local Bus Interface

The PCI-to-ISA bridge device provides an accelerated PCI-to-ISA interface that includes a high-performance enhanced IDE controller, PCI and ISA master/slave interfaces, enhanced DMA functions, and a plug-and-play port for onboard devices. The bridge device also provides many common I/O functions found in ISA-based PC systems, including a seven channel DMA controller, two 82C59 interrupt controllers, an 8254 timer/counter, and control logic for NMI generation.

Video Controller

The PCI bus video controller features a 64-bit graphics engine, with 24-bit RAMDAC for true color support. It has 2 MB of VRAM and supports resolutions up to 1280 x 1024 with 256K colors.

Fast IDE controller and Floppy Drive Controller

The enhanced IDE controller supports programmed I/O (PIO) and bus mastering DMA with transfer rates to 22 MB/second. The controller contains an 8 x 32 bit buffer for bus master IDE PCI burst transfers, and will support up to two IDE devices. This controller can also handle a single optional floppy drive device. If present, this floppy drive will be designated Drive A.

Caution

The IDE controller supports enhanced PIO modes, which reduce the cycle times for 16-bit data transfers to the hard drive. Check with your drive manual to see if the drive you are using supports these modes. The higher the PIO mode, the shorter the cycle time will be. As the IDE cable length increases, this reduced cycle time can lead to erratic operation. As a result, it is in your best interest to keep the IDE cable as short as possible.

The PIO modes are selected in the BIOS setup (see p. 32). The Autoconfig will attempt to classify the connected drive if the drive supports the auto ID command. If you experience problems, change the **Transfer Mode:** to *Standard*.

Caution

The total cable length must not exceed 18 inches. Also, if two drives are connected, they must be no more than six inches apart.

VMEbus Interface

The XVME-653/658 uses the PCI local bus to interface to the VMEbus. The VMEbus interface supports full DMA to and from the VMEbus, integral FIFOs for posted writes, block mode transfers, and read-modify-write operations. The interface contains one master and four slave images that can be programmed in a variety of modes to allow the VMEbus to be mapped into the XVME-653/658 local memory. This makes it easy to configure VMEbus resources in protected and real mode programs. The XVME-658 and the XVME-653/31x modules also incorporate onboard hardware byte-swapping (see Table 1-3).

Card Expansion Options

The XVME-653/658 supports optional PMC (PCI Mezzanine Card), PC/104, short ISA, or PCI expansion using XVME-976 expansion modules. The XVME-976/201 provides one PCI Mezzanine Card (PMC) site and one 16-bit PC/104 site. The XVME-976/202 provides one 16-bit short ISA expansion site. The XVME-976/203 provides two PMC sites. The XVME-976/204 provides two 16-bit PC/104 sites. The XVME-976/205 provides one PCI card expansion site. All XVME-976 modules are designed to plug directly into the XVME-653/658 using the 80-pin interboard connectors.

Onboard Memory

DRAM Memory

The XVME-653/658 has two 72-pin SIMM memory sites, providing up to 256 MB of DRAM. The memory sites can be populated with standard fast page mode memory or enhanced data out memory (EDO). EDO memory is designed to improve DRAM read

performance. Using EDO memory improves the back-to-back burst timing to 5-2-2-2 from the 5-3-3-3 of standard memory. The XVME-653/658 also supports error checking and correction (ECC) or parity checking DRAM memory. Approved DRAM suppliers are listed in Appendix A.

Secondary Cache

The XVME-653/658 comes equipped with 512 KB synchronous level 2 pipeline burst cache.

Flash BIOS

The XVME-653/658 system BIOS is contained in a 512 KB flash device to facilitate system BIOS updates. You can program and enable additional areas of the flash device to provide optional ROM support. You should contact Xycom Automation for more information on flashing option ROMs and video ROMs into the BIOS image.

ROM Site

This 32-pin onboard site supports nonvolatile SRAM and *DiskOnChip*.

Nonvolatile SRAM

The board supports 32K x 8 and 128K x 8 nonvolatile SRAM memory sizes. Packaged in a standard 32-pin DIP format, the SRAM contains a built-in battery and battery backup. Battery life is seven years minimum in absence of V_{CC} .

DiskOnChip

The *DiskOnChip* is a single-chip flash disk in a standard 32-pin DIP format. It requires an 8 KB window to view as an extension BIOS. During boot up, the *DiskOnChip* loads its software in the PC memory and installs itself as an additional drive. See **Error! Reference source not found.** 1–4 for *DiskOnChip* size options.

Universal Serial Bus Port

The XVME-653/658 incorporates a Universal Serial Bus (USB) port that is compatible with USB devices. The port terminates in a standard two-pin connector.

Serial and Parallel Ports

PC peripherals include two high-speed 16550-compatible serial ports and an ECP or EPP configurable parallel port.

Mouse Port

The XVME-653/658 includes a PS/2-compatible mouse port.

Keyboard Interface

The keyboard interface uses a PS/2-style connector on the front panel. The +5 V is protected with a polyswitch. This device will open up if the +5 V is shorted to GND. Once the shorting condition is removed, the polyswitch will allow current flow to resume.

Hard and Floppy Drives

The XVME-653/658 IDE hard drive and floppy drive signals are routed through the P2 connector, providing a simplified method of connecting external floppy and hard drives. The XVME-653/658 will support only one floppy drive.

When used with the XVME-977 mass storage module, the hard and floppy drives do not need to be located next to the processor. Using the supplied six-inch ribbon cable (which connects the XVME boards' J2 VME backplane connectors), the XVME-977 can be installed up to six slots away from the XVME-653/658 on the VME backplane. This allows greater flexibility in configuring the VMEbus card cage.

For applications that require mass storage outside the VMEbus chassis, the XVME-973/1 drive adapter module plugs onto the VMEbus J2 connector. This module provides industry standard connections for IDE and floppy signals. One floppy drive can be connected to the XVME-973/1. This drive may be 2.88 MB, 1.44 MB, 1.2 MB, or 360 KB in size. For more information on the XVME-973/1, refer to Chapter 5.

Caution

The total cable length must not exceed 18 inches. If two drives are connected, they must be no more than six inches apart.

Watchdog Timer

The XVME-653/658 incorporates a watchdog timer. When enabled, the timer can either generate an interrupt or a master reset, depending on how you configure the watchdog timer port. The timer input needs to be toggled within 1.6 seconds to prevent timeout.

Operational Description

Figure 1- 1 is the block diagram for the XVME-653/658.

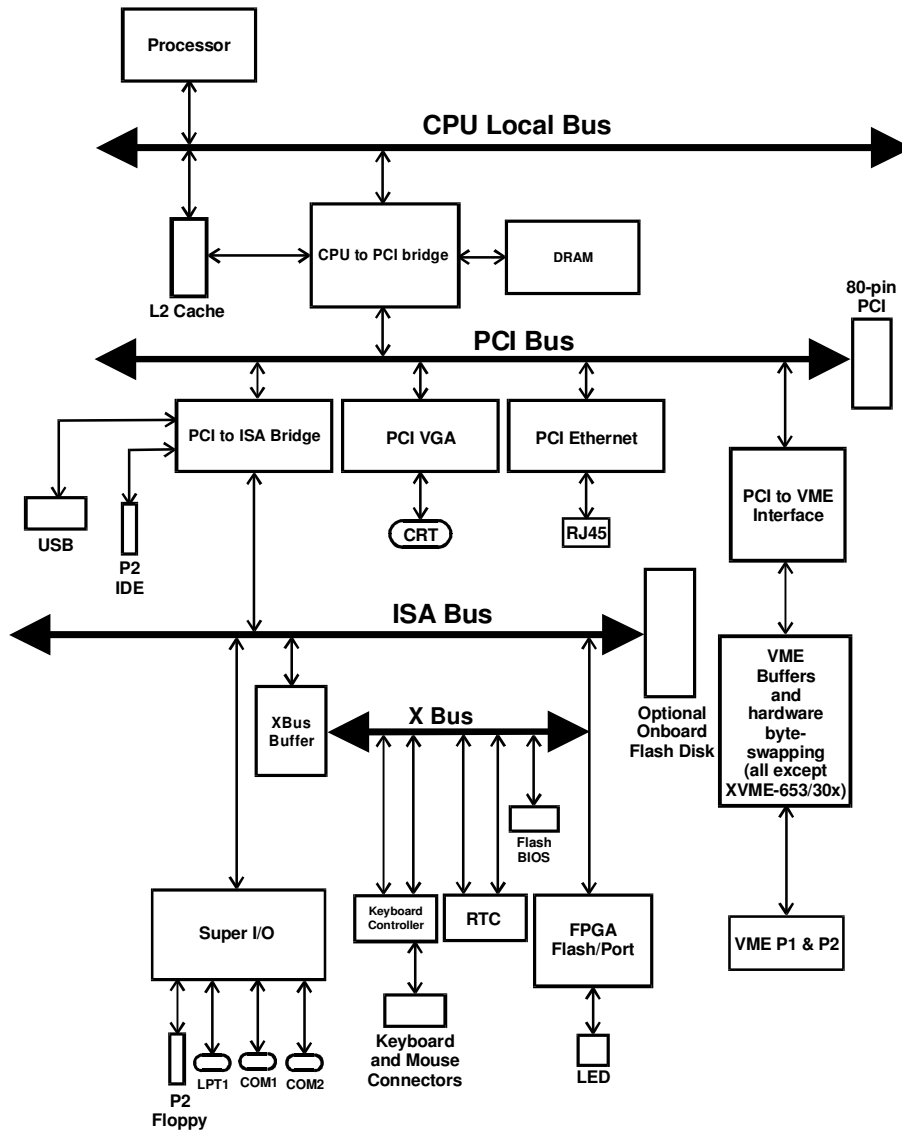

Figure 1- 1. XVME-653/658 Block Diagram

Environmental Specifications

Table 1- 1. Environmental Specifications

Characteristic	Specification
Temperature: Operating (100 cfm airflow) XVME-653 (Intel 233 MHz Pentium) XVME-658 (AMD 333 MHz K6-2) Non-operating	0 to 50°C (32 to 122°F) 0 to 45°C (32 to 113°F) -45 to 85°C (-49 to 185°F)
Vibration: Frequency Operating Non-operating	5 to 2000 Hz 0.015" (0.38 mm) peak-to-peak displacement 2.5 G (maximum) acceleration 0.030" (0.76 mm) peak-to-peak displacement 5.0 G (maximum) acceleration
Shock: Operating Non-operating	30 G peak acceleration, 11 msec duration 50 G peak acceleration, 11 msec duration
Humidity	20% to 80% RH, non-condensing

Hardware Specifications

Table 1- 2. Hardware Specifications

Characteristic	Specification
Power Specifications: +12V -12V +5V: XVME-653 (Intel 233 MHz Pentium) XVME-658 (AMD 333 MHz K6-2)	75 mA maximum 24 mA maximum 10.59 A (maximum); 5.87 A (typical) 10.59 A (maximum); 6.5 A (typical)
CPU speed: XVME-653 XVME-658	233 MHz 333 MHz
Cache	512 KB pipeline burst cache
Ethernet controller	Intel 82558 10/100 BaseTX Fast Ethernet; RJ-45
PCI Super VGA Graphics Controller	1280 x 1024 maximum resolution, 256 colors; 2 MB VRAM
Serial Ports	RS-232C, 16550 compatible (2) USB (1)
Parallel Interface	EPP/ECP compatible (1)
Onboard memory	Fast-page or EDO DRAM, ECC or parity, up to 256 MB
Regulatory Compliance	European Union Electromagnetic Compatibility - 89/336/EEC
VMEbus Compliance Complies with VMEbus Specification ANSI/VITA 1-1994 A32/A24/A16:D64/D32/D16/D08(EO) DTB Master A32/A24/A16:D64/D32/D16/D08(EO) DTB Slave R(0-3) Bus Requester Interrupter I(1)-I(7) DYN IH(1)-IH(7) Interrupt Handler SYSCLK and SYSRESET Driver PRI, SGL, RRS Arbiter RWD, ROR bus release Form Factor: Double-height, single-width 233 mm x 160 mm (9.2" x 6.3")	

System Configuration and Expansion Options Tables

Your XVME-653/658 can be ordered in a variety of configurations and expanded as well. The following tables show these options.

Table 1- 3. XVME-653/658 CPU and DRAM Configurations and Byte-Swapping Hardware

XVME-653 Intel 233 MHz Pentium CPU			XVME-658 AMD 333 MHz K6-2 CPU		
Ordering Number	Byte-Swapping Hardware?	DRAM	Ordering Number	Byte-Swapping Hardware?	DRAM
XVME-653/310	Yes	None	XVME-658/310	Yes	None
XVME-653/313	Yes	32 MB	XVME-658/313	Yes	32 MB
XVME-653/314	Yes	64 MB	XVME-658/314	Yes	64 MB
XVME-653/315	Yes	128 MB	XVME-658/315	Yes	128 MB
XVME-653/316	Yes	256 MB	XVME-658/316	Yes	256 MB
XVME-653/300	No	None			
XVME-653/303	No	32 MB			
XVME-653/304	No	64 MB			
XVME-653/305	No	128 MB			
XVME-653/306	No	256 MB			

The ordering number is broken into two parts. The model number is the 653 or 658. The tab number is the three digits after the slash. For the XVME-653/658, the tab number indicates the presence of byte-swapping hardware (the second digit is a one if the unit has byte-swapping hardware, otherwise it is a zero) and the amount of DRAM memory (the third digit). DRAM options are explained more fully in Appendix A.

There are also several expansion options for the XVME-653/658.

Table 1- 4. XVME-653/658 Expansion Options

Ordering Number	Description
XVME-973/1	Drive Adapter Module for external drives
XVME-976/201	PMC and PC/104 Expansion Module
XVME-976/202	16-bit short ISA Expansion Module
XVME-976/203	Dual PMC Expansion Module
XVME-976/204	Dual PC/104 Expansion Module
XVME-976/205	PCI Carrier Module
XVME-977	Single-slot Mass Storage Module
XVME-992/8	8 MB <i>DiskOnChip</i>
XVME-992/24	24 MB <i>DiskOnChip</i>
XVME-992/40	40 MB <i>DiskOnChip</i>
XVME-992/72	72 MB <i>DiskOnChip</i>
XVME-992/144	144 MB <i>DiskOnChip</i>

The XVME-976 expansion modules and the XVME-977 module are described in their own manuals. The XVME-973/1 is described in Chapter 5.

Chapter 2 – Installation

This chapter provides information on configuring the XVME-653/658 modules. It also provides information on installing the XVME-653/658 into a backplane and enabling the Ethernet controller. Figure 2-1 and Figure 2-2 illustrate the jumper, switch, and connector locations on the XVME-653/658. Note that the version of the XVME-653 module without the byte-swapping hardware has three jumpers in slightly different positions.

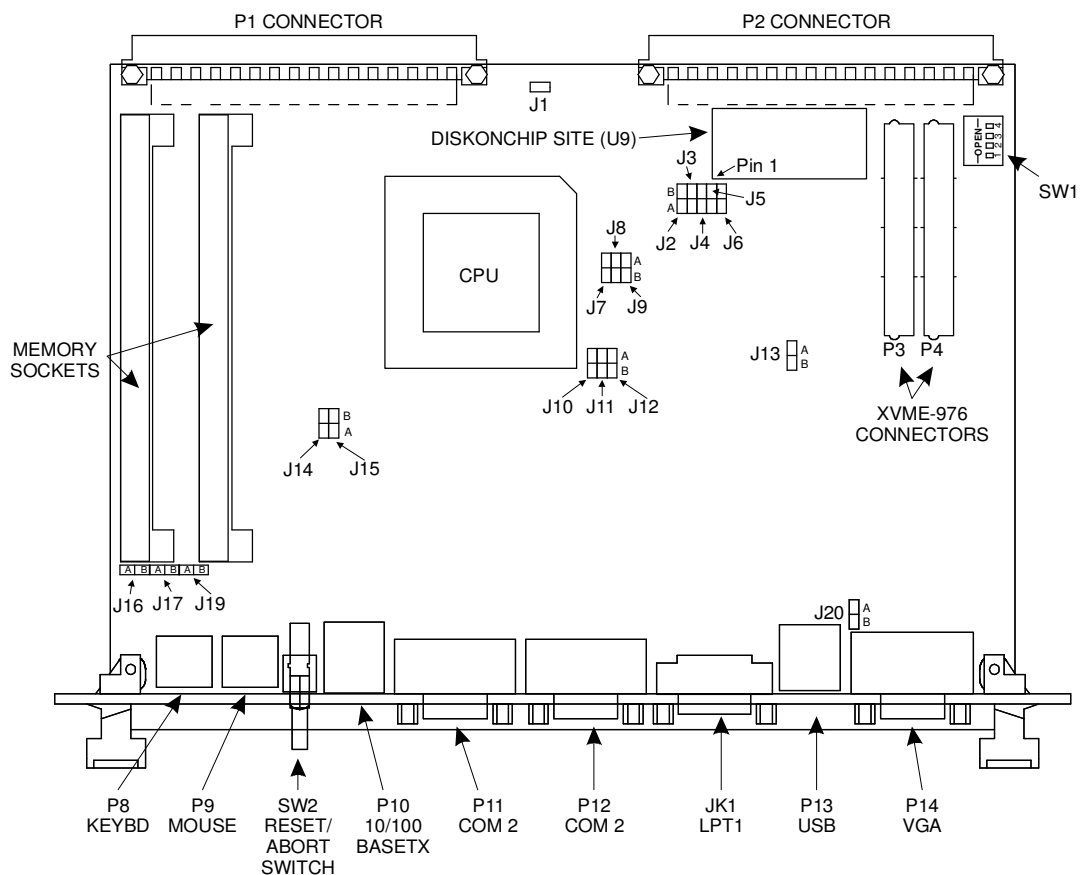

Figure 2- 1. XVME-653/658 Jumper, Switch, and Connector Location

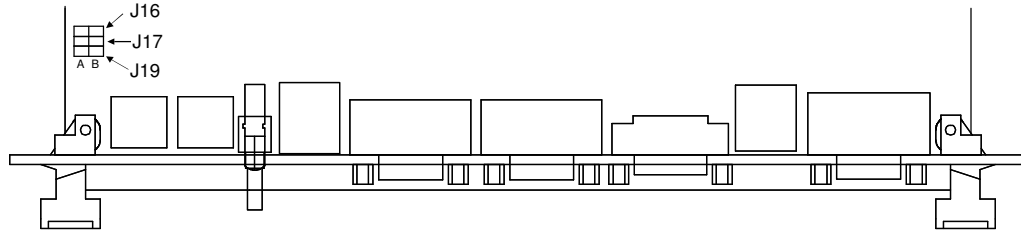

Figure 2- 2. J16, J17, and J19 Jumper Locations for XVME-653/30x (no byte-swapping hardware)

Jumper Settings

The following tables list the XVME-653/658 jumpers, their default positions (either checked or labeled by module number), and their functions. Jumper locations are shown in Figure 2- 1 and Figure 2- 2.

Table 2- 1. General Jumper Settings

Jumper	Position	Function
J1	In Out ✓	Disables system resource function Enables system resource function
J13	A ✓ B	Reserve 1
J16	A ✓ B	Boot from Flash Boot from ROM
J17	A B ✓	Clear CMOS memory Normal CMOS memory
J19	A ✓ B	Reserve 2
J20	A B ✓	Reserve 3

CPU Configuration

Table 2- 2. CPU Configuration Jumper Settings

Module/Speed	J2	J3	J4	J5	J6	J7	J8	J9	J10	J11	J12
XVME-653/233 MHz	B	A	A	A	A	B	B	B	A	A	A
XVME-658/333 MHz	A	A	B	A	A	B	B	B	B	A	B

CPU Core Voltage

Table 2- 3. CPU Core Voltage Jumper Settings

CPU Core Voltage	J2	J3	J4	J5	J6
2.2 V (XVME-658/333 MHz)	A	A	B	A	A
2.8 V (XVME-653/233 MHz)	B	A	A	A	A

CPU Voltage Plane Configuration

Table 2- 4. CPU Voltage Plane Configuration Jumper Settings

CPU Configuration	J7	J8	J9
Single Voltage Plane	A	A	A
Split Voltage Planes (XVME-653/658) ✓	B	B	B

Processor Speed

Table 2- 5. Processor Speed Jumper Settings

Processor Speed	J10	J11	J12
3/2x (XVME-653/233 MHz)	A	A	A
5x (XVME-658/333 MHz)	B	A	B

Memory

Table 2- 6. Memory Voltage Jumper Settings

Memory	J14	J15
5.0 V ✓	A	A
3.3 V	B	B

Switch Settings

The XVME-653/658 has one four-pole switch (SW1). This switch controls the system response to the front panel **Reset** switch (SW2). Table 2-7 shows the switch settings required to reset on the XVME-653/658 CPU, to reset only the VME backplane, or to reset both. The switch 3 is reserved and should always be closed. The XVME-653/658 is shipped with all four switches in the closed position (which causes SW2 to reset both the XVME-653/658 and the VME backplane). Both switches are shown in Figure 2-1.

Table 2- 7. Four-Pole Switch (SW1) Settings

For the front panel reset switch (SW2) is to do this:	The four-pole switch (SW1) settings must be:		
	1	2	4
No Resets	Closed	Open	Open
Reset the VME backplane only*	Open	Closed	Open
Reset the XVME-653/658 CPU only**	Closed	Open	Closed
Reset both the VME backplane and the XVME-653/658 CPU (default setting)	Closed ✓	Closed ✓	Closed ✓

Caution

Resetting only the VME backplane will reset the Universe chip.

Caution

If you have an older XVME-653, which has a Tundra Universe chip instead of a Tundra Universe II chip (U19), you do not have the ability to reset the CPU only. The option to reset both the CPU and the VME backplane still works normally.

You can tell a Universe from a Universe II by looking at the model number on the top of the chip. The Universe has CA91C042-33CE and the Universe II has CA91C142-33CE.

Registers

The XVME-653/658 contains four I/O port registers: 218h, 219h, 233h, and 234h.

Register 218h – Abort/Clear CMOS Port

This register controls the abort toggle switch and allows you to read the CMOS clear jumper (J17).

Table 2- 8. Abort/Clear CMOS Port Register Settings

Bit	Signal	Result	R/W
0	RESERVED	Reserved	
1	RESERVED	Reserved	
2	RESERVED	Reserved	
3	RESERVED	Reserved	
4	ABORT_STS	1 = Abort toggle switch caused interrupt	R
5	ABORT_CLR	0 = Clear and disable abort 1 = Enable abort	R/W
6	RESERVED	Reads jumper J13	R
7	CLRCMOS	0 = Clear CMOS 1 = CMOS okay	R

Register 219h – LED/BIOS Port

This register controls the following LEDs and signals.

Table 2- 9. LED/BIOS Port Register Settings

Bit	LED/Signal	Result	R/W
0	FAULT	0 = Fault LED on 1 = Fault LED off	R/W
1	PASS	0 = PASS LED off 1 = PASS LED on	R/W
2	FLB_A18_EN	1 = Flash write enabled and A18 is controllable	R/W
3*	FLB_A18/reserve2	Reads jumper J19 when FLB_A18_EN = 0 Flash BIOS address A18 when FLB_A18_EN = 1	R/W
4	RESERVED	Reserved	
5	BIOS_D0	1 = Enable UPPER on board BIOS area @D0000	R/W
6	RESERVED	Reserved	
7	RESERVED	Reserved	

Note

A18, along with control ROM/RAM 15-17 are to be used to page the Flash when FLB_A18_EN is asserted.

Register 233h – Watchdog Timer Port

This register controls watchdog timer operation.

Table 2- 10. Watchdog Timer Port Register Settings

Bit	Signal	Result
0	RESERVED	Reserved
1	RESERVED	Reserved
2	RESERVED	Reserved
3	RESERVED	Reserved
4	WDOG_EN	Enables the watchdog timer
5	MRESET_EN	Timeout generates reset when asserted
6	WDOG_STS	Watchdog timer status bit
7	WDOG_CLR	Clears the watchdog timer

Register 234h – NVRAM and DiskOnChip Port

This register controls access to either the NVRAM or the *DiskOnChip* (DOC) component. Bits 7 and 8 also control the byte swapping on XVME-653/658 modules that are equipped with byte-swapping hardware. In XVME-653/30x modules without byte-swapping hardware, bits 7 and 8 are RESERVED.

Table 2- 11. NVRAM and DiskOnChip Port Register Settings

Bit	Signal	Result
0	Control ROM/RAM15	ROM address 15 - page control bit
1	Control ROM/RAM16	ROM address 16 - page control bit
2	Control ROM/RAM17	ROM address 17 - page control bit
3	DOC enable	Enables DOC mode
4	Range select 0	
5	Range select 1	
6	SWAPS	1 = No swapping (no swapping= no data invariance) occurs during Slave cycles. (This byte can only be set for byte-swapping modules.)
7	SWAPM	1 = No swapping (no swapping= no data invariance) occurs during Master cycles. (This byte can only be set for byte-swapping modules.)

The following table lists ranges that are defined by bits 4 and 5 in register 234h, as well as byte-swapping bits 6 and 7.

Table 2- 12. Register 234h Defined Ranges

Range Select Bits		
Bit 5	Bit 4	Range
0	0	No range
0	1	CC000-CFFFF
1	0	D0000-D7FFF
1	1	D8000-DFFFF

Byte-Swapping Bits		
Bit 7	Bit 6	Description
0	0	Byte swap all*
0	1	Byte swap master
1	0	Byte swap slave
1	1	Byte swap none

* Same as non-byte swap board

Connectors

This section provides the pinouts for the XVME-653/658 connectors. Refer to the EMC warning at the beginning of this manual before attaching cables.

Serial Port Connectors

Table 2- 13. Serial Port Connector Pinout

COM1		COM2	
Pin	Signal	Pin	Signal
1	DCD1	1	DCD2
2	RXD1	2	RXD2
3	TXD1	3	TXD2
4	DTR1	4	DTR2
5	GND	5	GND
6	DSR1	6	DSR2
7	RTS1	7	RTS2
8	CTS1	8	CTS2
9	RI1	9	RI2

Parallel Port Connector

Table 2- 14. Parallel Port Connector Pinout

Pin	Signal	Pin	Signal
1	STROBE	14	AUTOFEED
2	PDOUT0	15	PERROR
3	PDOUT1	16	INIT
4	PDOUT2	17	SELIN
5	PDOUT3	18	GND
6	PDOUT4	19	GND
7	PDOUT5	20	GND
8	PDOUT6	21	GND
9	PDOUT7	22	GND
10	PACK	23	GND
11	PBUSY	24	GND
12	PE	25	GND
13	SELECT		

USB Port Connector

Table 2- 15. USB Port Connector Pinout

Pin	Signal
1A	+5V
2A	USBP0-
3A	USBP0+
4A	GND
1B	+5V
2B	USBP1-
3B	USBP1+
4B	GND

VGA Connector

Table 2- 16. VGA Connector Pinout

Pin	Signal
1	RED
2	GREEN
3	BLUE
4	NC
5	GND
6	GND
7	GND
8	GND
9	25MIL_VIDA
10	GND
11	NC
12	LDDCDAT
13	HYSNC
14	VSYNC
15	LDDCCLK

Keyboard Port Connector

Table 2- 17. Keyboard Port Connector Pinout

Pin	Signal
1	DATA
2	NC
3	GND
4	+5V
5	CLK
6	NC

Auxiliary Connector

The auxiliary port accepts a PS/2-compatible mouse, track ball, etc.

Table 2- 18. Auxiliary Port Connector Pinout

Pin	Signal
1	DATA
2	NC
3	GND
4	VCC
5	CLK
6	NC

VMEbus Connectors

P1 and P2 are the VMEbus connectors.

P1 Connector

Table 2- 19. P1 Connector Pinout

Pin	A	B	C
1	D00	BBSY*	D08
2	D01	BCLR*	D09
3	D02	ACFAIL*	D10
4	D03	BG0IN*	D11
5	D04	BG0OUT*	D12
6	D05	BG1IN*	D13
7	D06	BG1OUT*	D14
8	D07	BG2IN*	D15
9	GND	BG2OUT*	GND
10	SYSCLK	BG3IN*	SYSFAIL*
11	GND	BG3OUT*	BERR*
12	DS1*	BR0*	SYSRESET*
13	DS0*	BR1*	LWORD*
14	WRITE*	BR2*	AM5
15	GND	BR3*	A23
16	DTACK*	AM0	A22
17	GND	AM1	A21
18	AS*	AM2	A20
19	GND	AM3	A19
20	IACK*	GND	A18
21	IACKIN*	NC	A17
22	IACKOUT*	NC	A16
23	AM4	GND	A15
24	A07	IRQ7*	A14
25	A06	IRQ6*	A13
26	A05	IRQ5*	A12
27	A04	IRQ4*	A11
28	A03	IRQ3*	A10
29	A02	IRQ2*	A09
30	A01	IRQ1*	A08
31	-12V	NC	+12V
32	+5V	+5V	+5V

P2 Connector

Table 2- 20. P2 Connector Pinout

Pin	A	B	C
1	+5V	+5V	HDBRSTDRV*
2	+5V	GND	HDD0
3	+5V	RES	HDD1
4	RES	VA24	HDD2
5	RES	VA25	HDD3
6	RES	VA26	HDD4
7	RES	VA27	HDD5
8	RES	VA28	HDD6
9	RES	VA29	HDD7
10	RES	VA30	HDD8
11	RES	VA31	HDD9
12	RES	GND	HDD10
13	RES	+5V	HDD11
14	RES	VD16	HDD12
15	RES	VD17	HDD13
16	RES	VD18	HDD14
17	RES	VD19	HDD15
18	RES	VD20	GND
19	GND	VD21	HDIOW*
20	FRWC*	VD22	HDIOR*
21	IDX*	VD23	HDIORDY
22	MO0*	GND	+5V (10K pullup)
23	HDRQ0	VD24	IRQ14
24	FDS0*	VD25	RES
25	HDACK0*	VD26	DA0
26	FDIRC*	VD27	DA1
27	FSTEP*	VD28	DA2
28	FWD*	VD29	CS1P*
29	FWE*	VD30	CS3P*
30	FTK0*	VD31	RES
31	FWP*	GND	FHS*
32	FRDD*	+5V	DCHG*

Interboard Connector 1 (P4)

Table 2- 21. Interboard Connector 1 Pinout

Pin	Signal	Pin	Signal
1	SYSCLOCK	41	SA10
2	OSC	42	SA11
3	SD(15)	43	SA12
4	SD(14)	44	SA13
5	SD(13)	45	SA14
6	SD(12)	46	SA15
7	SD(11)	47	SA16
8	SD(10)	48	SA17
9	SD(9)	49	SA18
10	SD(8)	50	SA19
11	MEMW*	51	BALE
12	MFMR*	52	TC
13	DRQ5	53	DACK2*
14	DACK5*	54	IRQ3
15	DRQ6	55	IRQ4
16	DACK6*	56	SBHE*
17	LA17	57	IRQ5
18	LA18	58	IRQ6
19	LA19	59	IRQ7
20	LA20	60	RFF*
21	LA21	61	DRQ1
22	LA22	62	DACK1*
23	LA23	63	RESETD
24	IRQ14	64	IOW*
25	IRQ15	65	IOR*
26	IRQ12	66	SMFMW*
27	IRQ11	67	AEN
28	IRQ10	68	SMEMR*
29	IOCS16*	69	IOCHRD
30	MEMCS1	70	SD0
31	SA0	71	SD1
32	SA1	72	SD2
33	SA2	73	SD3
34	SA3	74	SD4
35	SA4	75	SD5
36	SA5	76	SD6
37	SA6	77	SD7
38	SA7	78	DRQ2
39	SA8	79	IRQ9
40	SA9	80	IOCHCK*

Interboard Connector 2 (P3)

This connector provides power through the center pins.

Table 2- 22. Interboard Connector 2 Pinout

Pin	Signal	Pin	Signal
1	TCLK	41	AD23
2	TRST*	42	AD22
3	TMS	43	AD21
4	TDO	44	AD20
5	TDI	45	AD19
6	PCI-RSVD9A (Pn2-8)	46	AD18
7	PCI-RSVD10B (Pn2-9)	47	AD17
8	PCI-RSVD11A (Pn2-10)	48	AD16
9	PCI-RSVD14A (Pn1-12)	49	BE2*
10	PCI-RSVD14B (Pn1-10)	50	FRAME*
11	PCI-RSVD19A (Pn2-17)	51	IRDY*
12	PMC-RSVD Pn2-34	52	TRDY*
13	PMC-RSVD Pn2-52	53	DEVSEL*
14	PMC-RSVD Pn2-54	54	STOP*
15	PCICLK3	55	PLOCK*
16	PIRQA*	56	PERR*
17	PIRQB*	57	SDONE
18	PIRQC*	58	SBO*
19	PIRQD*	59	SERR*
20	REQ3*	60	PAR
21	PCICLK2	61	BE1*
22	REQ1*	62	AD15
23	GNT3*	63	AD14
24	PCICLK1	64	AD13
25	GNT1*	65	AD12
26	PCIRST*	66	AD11
27	PCICLK0	67	AD10
28	GNT0*	68	AD9
29	REQ0*	69	AD8
30	REQ2*	70	BE0*
31	AD31	71	AD7
32	AD30	72	AD6
33	AD29	73	AD5
34	AD28	74	AD4
35	AD27	75	AD3
36	AD26	76	AD2
37	AD25	77	AD1
38	AD24	78	AD0
39	BE3*	79	ACK64*
40	GNT2*	80	REQ64*

Installing the XVME-653/658 into a Backplane

This section provides the information necessary to install the XVME-653/658 into the VMEbus backplane. The XVME-653/658 is a double-high, single board VMEbus module that occupies one VMEbus slot.

Note

Xycom Automation XVME modules are designed to comply with all physical and electrical VMEbus backplane specifications.

Caution

Do not install the XVME-653/658 on a VMEbus system without a P2 backplane.

Warning

Never install or remove any boards before turning off the power to the bus and all related external power supplies.

1. Disconnect all power supplies to the backplane and the card cage. Disconnect the power cable.
2. Make sure backplane connectors P1 and P2 are available.
3. Verify that all jumper settings are correct.
4. Verify that the card cage slot is clear and accessible.
5. Install the XVME-653/658 in the card cage by centering the unit on the plastic guides in the slots (P1 connector facing up). Push the board slowly toward the rear of the chassis until the P1 and P2 connectors engage. The board should slide freely in the plastic guides.

Caution

Do not use excessive force or pressure to engage the connectors. If the boards do not properly connect with the backplane, remove the module and inspect all connectors and guide slots for damage or obstructions.

6. Secure the module to the chassis by tightening the machine screws at the top and bottom of the board.
7. Connect all remaining peripherals by attaching each interface cable into the appropriate connector on the front of the XVME-653/658 board as shown in **Error! Reference source not found.**2-23.

8. Turn on power to the VMEbus card cage.

Table 2- 23. Front Panel Connector Labels

Connector	Label
Keyboard	KEYBD
Mouse	MOUSE
Ethernet cable	100BT
Serial devices	COM 1, COM 2
Parallel device	LPT1
USB cable	USB
Display cable	VGA

Note

The floppy drive and hard drive are either cabled across P2 to the XVME-977 disk unit, or they are connected to the XVME-973/1 board. Refer to Chapter 5 for more information on the XVME-973/1.

Figure 2- 3 illustrates the XVME-653/658 front panel, to help you locate connectors.

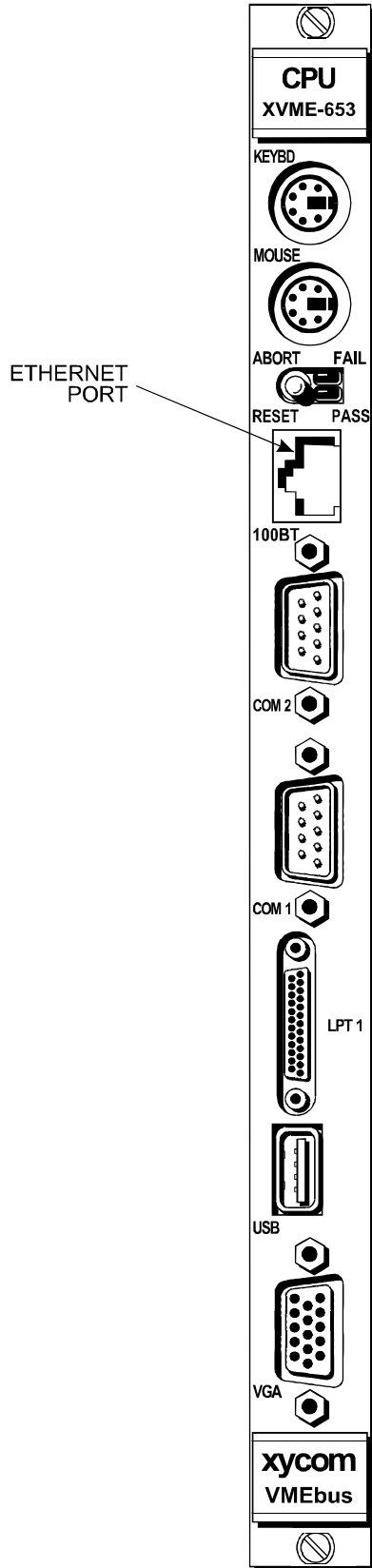

Figure 2-3. XVME-653/658 Front Panel

Enabling the PCI Ethernet Controller

The XVME-653/658 incorporates a high-performance 32-bit PCI bus mastering Ethernet controller.

Loading the Ethernet Driver

To enable the Ethernet controller, you must load the applicable Ethernet driver for your operating system. Refer to the READMEFIRST.TXT file on the Intel 558 Ethernet Drivers disk for installation instructions. For best results, always use the supplied drivers.

Pinouts for the RJ-45 10/100 BaseT Connector

Table 2- 24. RJ-45 10/100 BaseT Connector Pinout

Pin	Signal
1	TX+
2	TX-
3	RX+
4	GND
5	GND
6	RX-
7	GND
8	GND

Using a DiskOnChip

The *DiskOnChip* device is a self-contained solid-state disk drive that is packaged in a 32-pin device. It can be plugged into the onboard SRAM/Flash socket.

Perform the following steps to configure the XVME-653/658 to use a *DiskOnChip*:

1. Plug the *DiskOnChip* into socket U9 on the CPU module. Be sure the direction is correct (pin 1 of the *DiskOnChip* is aligned with pin 1 of the socket).
2. Turn on the system and enter the BIOS setup menus. (See Chapter 3 for information on accessing the BIOS setup menus.)
3. Select the Advanced menu option from the BIOS Setup main screen.
4. Select the Integrated peripherals option.
5. Select the 32-pin ROM site option.
6. Set the 32-pin ROM site type to DiskOnChip.
7. Set the 32-pin ROM site address to the desired value.
8. Exit the BIOS setup menus and reboot the system.

If the *DiskOnChip* is the only drive in the system, it will appear as the first disk (drive C: in DOS). If there are other drives in the system, the *DiskOnChip* will appear by default as the last drive, unless it is programmed as the first drive.

If you want the *DiskOnChip* to be bootable, copy the operating system files into it using the standard DOS command (for example *sys d*).

The *DiskOnChip* works with MS-DOS, Windows 3.11, and Windows NT. To fit a version of Windows NT onto the *DiskOnChip* (72 MB minimum), reduce the size of the Windows NT space requirement with a utility such as VenturCom *Component Integrator*[™]. If you use another operating system, please visit the M-Systems web site at www.m-sys.com or contact Xycom Automation Application Engineering at 734-429-4971 ext. 595.

Chapter 3 – BIOS Setup Menus

The XVME-653/658 customized BIOS is designed to surpass the functionality provided for normal PCs. This custom BIOS allows you to access the value-added features on the XVME-653/658 module without interfacing to the hardware directly.

Getting to the BIOS Setup Menus

If the setup prompt is disabled on your system (the default setting) press F2 repeatedly after the memory tests and before your system loads the operating system in order to access the main menu.

If the setup prompt is enabled on your system, the BIOS displays the following message: *Press F2 to enter Setup*. Once this message appears, press F2 to access the main menu.

The BIOS Main Setup Menu is shown on the next page.

Moving through the Menus

General instructions for navigating through the screens are described below:

Key	Result
F1 or ALT-H	Accesses the general Help window
ESC	Exits the menu
← or → arrow keys	Selects a different menu
↑ or ↓ arrow keys	Moves the cursor up or down
TAB or SHIFT-TAB	Cycles the cursor up or down
HOME or END	Moves the cursor to the top or bottom of the window
PGUP or PGDN	Moves the cursor to the next or previous page
F5 or -	Selects the previous value for the field
F6 or + or SPACE	Selects the next value for the field
F9	Loads the default configuration values for the menu
F10	Loads the previous configuration values for the menu
ENTER	Executes the Command or Selects a ▶ Submenu

To select an item, use the arrow keys to move the cursor to the field you want. Then use the TAB, SHIFT-TAB, or ENTER keys to select a subfield, if any. Then use the + and – keys or the F5 and F6 keys to select a value for that field. The **Save Changes** commands in the **Exit Menu** save the values currently displayed in all the menus.

To display a submenu, use the arrow keys to move the cursor to the submenu you want. Then press ENTER. A triangle bullet (▶) indicates a submenu.

BIOS Main Setup Menu

PhoenixBIOS Setup-Copyright 1985-95 Phoenix Technologies Ltd.				
Main	Advanced	Security	VMEbus	Exit
System Time: [16:19:20] System Date: [03/02/95] Diskette A: [1.44 MB, 3½"] ▶ IDE Adapter 0 Master (C: 260 Mb) ▶ IDE Adapter 0 Slave (D:105 Mb) ▶ IDE Adapter 1 Master (None) ▶ IDE Adapter 1 Slave (None) Video System: [EGA/VGA] ▶ Memory Cache ▶ Memory Shadow ▶ Boot sequence: [A: then C:] ▶ Numlock: [Auto] System Memory: 640 KB Extended Memory: 63 MB				Item Specific Help <i>If the line item you are viewing has specific help, it will be listed here.</i>
F1 Help	↑↓	Select Item	-/+	Change Values
ESC Exit	←→	Select Menu	Enter	Select ▶ Submenu
			F9	Setup Defaults
			F10	Previous Values

Figure 3- 1. Main Setup Menu

Note

IDE Adapter 1 (the secondary IDE controller) is not available to the XVME-653/658.

Table 3- 1. Main Setup Menu Options

Option	Description
System Time (HH/MM/SS)	Sets the real-time clock for hour, minute, and seconds. The hour is calculated according to the 24-hour military clock (i.e., 00:00:00 through 23:59:59). Use TAB to move right and SHIFT-TAB to move left. The ENTER key may be used to move from one field to the next. The numeric keys, 0-9, are used to change the field values. The F6 and the + keys may also be used to increment the values, while the F5 and the – keys may be used to decrement them. It is not necessary to enter the seconds or type zeros in front of numbers.
System Date (MM/DD/YYYY)	Sets the real-time clock for the month, day, and year. Use TAB to move right and SHIFT-TAB to move left. The ENTER key may be used to move from one field to the next. The numeric keys, 0-9, are used to change the field values. The F6 and the + keys may also be used to increment the values, while the F5 and the – keys may be used to decrement them. It is not necessary to type zeros in front of numbers.
Diskette A or B	Selects the floppy disk drive installed in your system. The XVME-653/658 can only support one floppy drive (Drive A).
Video System	Selects the default video device.
System Memory	Displays the amount of conventional memory detected during boot-up. This field is not user configurable.
Extended Memory	Displays the amount of extended memory detected during boot-up. This field is not user configurable.

IDE Adapter 0 Master and Slave Submenus

The IDE Adapter 0 Master and Slave submenus are used to configure IDE hard drive information. If only one drive is attached to the IDE adapter, then only the parameters in the Master Submenu need to be entered. If two drives are connected, both Master and Slave Submenu parameters will need to be entered. The Master and Slave Submenus contain the same information.

PhoenixBIOS Setup-Copyright 1985-95 Phoenix Technologies Ltd.	
Main	
IDE Adapter 0 Master (C: 850 Mb)	Item Specific Help
Autotype Fixed Disk: [Press Enter]	<i>If the line item you are viewing has specific help, it will be listed here.</i>
Type: [User] 850 Mb	
Cylinders: [1647]	
Heads: [16]	
Sectors/Track: [63]	
Write Precomp: [None]	
Multi-Sector Transfers: [8 Sectors]	
LBA Mode Control: [Enabled]	
32 Bit I/O: [Disabled]	
Transfer Mode: [Standard]	

F1 Help	↑↓ Select Item	-/+ Change Values	F9 Setup Defaults
ESC Exit	←→ Select Menu	Enter Select ▶ Submenu	F10 Previous Values

Figure 3- 2. IDE Adapter Submenu

Table 3- 2. IDE Adapter Submenu Options

Option	Description
Autotype Fixed Disk	Reads the hard disk parameters from the drive if you press ENTER. It then sets the Type field to User and lets you edit the other fields. Do not attempt to manually set the disk drive parameters unless instructed to do so by Xycom Application Engineering.
Type	Options include 1 to 39, User, or Auto. The 1 to 39 option fills in all remaining fields with values for predefined disk type. User prompts you to fill in remaining fields. Auto autotypes at each boot, displays settings in setup menus, and does not allow you to edit the remaining fields.
Cylinders	Indicates the number of cylinders on the hard drive. This information is automatically entered if the Autotype Fixed Disk option is set.
Heads	Indicates the number of read/write heads on the hard drive. This information is automatically entered if the Autotype Fixed Disk option is set.
Sectors/Track	Indicates the number of sectors per track on the hard drive. This information is automatically entered if the Autotype Fixed Disk option is set.
Write Precomp	This value is not used or required by IDE hard drives.
Multi-Sector Transfers	Sets the number of sectors per block. Options are Auto, 2, 4, 8, or 16 sectors. Auto sets the number of sectors per block to the highest number supported by the drive.
LBA Mode Control	Enables Logical Block Access. The default (Disabled) should work with most hard drives.
32 Bit I/O	Enables 32-bit communication between CPU and IDE interface.
Transfer Mode	Selects the method for transferring the data between the hard disk and system memory. Available options are determined by the drive type and cable length.

Memory Cache Submenu

Enabling cache increases CPU performance by holding data most recently accessed in a special high-speed static RAM area called cache. The XVME-653/658 provides two levels of cache memory; level one is internal to the CPU (see the **CPU Chip** section in Chapter 1), and level two (external cache) is 512 KB of high-speed cache memory.

PhoenixBIOS Setup-Copyright 1985-95 Phoenix Technologies Ltd.	
Main	
Memory Cache	Item Specific Help
External Cache: [Enabled]	<i>If the line item you are viewing has specific help, it will be listed here.</i>
Cache System BIOS area: [Enabled]	
Cache Video BIOS area: [Enabled]	
Cache Memory Region	
CC00-CFFF: [Disabled]	
D000-D3FF: [Disabled]	
D400-D7FF: [Disabled]	
D800-DBFF [Disabled]	
DC00-DFFF: [Disabled]	
F1 Help ↑↓ Select Item -/+ Change Values F9 Setup Defaults	
ESC Exit ←→ Select Menu Enter Select ▶ Submenu F10 Previous Values	

Figure 3- 3. Memory Cache Submenu

Table 3- 3. Memory Cache Submenu Options

Option	Description
External Cache	Controls the state of external cache memory. The system BIOS automatically disables external cache if it is not installed. The default is <i>Enabled</i> .
Cache System BIOS Area	Allows the system BIOS memory area to be cached if <i>Enabled</i> . Enabling also increases system performance. The default is <i>Enabled</i> .
Cache Video BIOS Area	Allows the video BIOS memory area to be cached if <i>Enabled</i> . Enabling also increases system performance. The default is <i>Enabled</i> .
Cache Memory Region	Caches the corresponding memory when <i>Enabled</i> . Memory in this area is usually extended BIOS or AT-bus memory. Enabling cache may increase system performance, depending on how the extended BIOS is accessed. The default is <i>Disabled</i> .

Memory Shadow Submenu

The summary screen displays the amount of shadow memory in use. Shadow memory is used to copy system and/or video BIOS into RAM to improve performance. The XVME-653/658 displays the number of KB allocated to Shadow RAM on the summary screen. The System Shadow field, which is not editable, is for reference only.

The XVME-653/658 is shipped with both the system BIOS and video BIOS shadowed.

PhoenixBIOS Setup-Copyright 1985-95 Phoenix Technologies Ltd.		
Main		
	Memory Shadow	Item Specific Help
System Shadow:	Enabled	<i>If the line item you are viewing has specific help, it will be listed here.</i>
Video Shadow:	Enabled	
Regions with Legacy Expansion Roms		
F1 Help	↑↓ Select Item	-/+ Change Values
ESC Exit	←→ Select Menu	Enter Select ▶ Submenu
		F9 Setup Defaults
		F10 Previous Values

Figure 3- 4 Memory Shadow Submenu

Table 3- 4. Memory Shadow Submenu Options

Option	Description
System Shadow	Permanently <i>Enabled</i> .
Video Shadow	Permanently <i>Enabled</i> .
Regions with Legacy Expansion ROMs	Regions are listed below the header if detected by the BIOS

Numlock Submenu

PhoenixBIOS Setup-Copyright 1985-95 Phoenix Technologies Ltd.			
Main			
Keyboard Features		Item Specific Help	
Numlock:	[Auto]	<i>If the line item you are viewing has specific help, it will be listed here.</i>	
Key Click:	[Disabled]		
Keyboard auto-repeat rate:	[30/sec]		
Keyboard auto-repeat delay:	[1/2 sec]		
F1 Help	↑↓ Select Item	-/+ Change Values	F9 Setup Defaults
ESC Exit	←→ Select Menu	Enter Select ▶ Submenu	F10 Previous Values

Figure 3- 6. Numlock Submenu

Table 3- 6. Numlock Submenu Options

Option	Description
Numlock	Determines how the BIOS defines the numlock key at power up or soft reset. Normally, the BIOS sets the numlock on (numeric keys selected) if it detects a 101- or 102-key keyboard at power up. If it detects an 84-key keyboard, it turns numlock off (cursor keys selected). Select <i>Auto</i> to keep this state, <i>On</i> to select the numeric keys regardless of keyboard, or <i>Off</i> to select cursor keys regardless of keyboard. The default is <i>Auto</i> .
Keyboard click	Provides audible keypress feedback by having the BIOS click through the system speaker every time a key is pressed, if <i>Enabled</i> . This option is only valid for systems with a speaker connected to the speaker jack. The default is <i>Disabled</i> .
Keyboard auto-repeat rate	Defines the rate at which the keyboard repeats while a key is pressed. The higher the number, the faster the key repeats. The default is <i>30/sec</i> , or 30 times per second.
Keyboard auto-repeat delay	Sets the delay time after a key is held down, before it begins to repeat the keystroke. The default is a <i>1/2 sec</i> .

Advanced Menu

This menu allows you to change the peripheral control, advanced chipset control, and disk access mode.

PhoenixBIOS Setup-Copyright 1985-95 Phoenix Technologies Ltd.				
Main	Advanced	Security	VMEbus	Exit
<p style="text-align: center;">Warning!</p> <p>Setting items on this menu to incorrect values may cause your system to malfunction.</p> <p>▶ Integrated Peripherals</p> <p>▶ Advanced Chipset Control</p> <p>Plug & Play O/S [No]</p> <p>Reset Configuration Data [No]</p> <p>Large Disk Access Mode: [DOS]</p>				<p style="text-align: center;">Item Specific Help</p> <p><i>If the line item you are viewing has specific help, it will be listed here.</i></p>
F1 Help	↑↓	Select Item	-/+	Change Values
ESC Exit	←→	Select Menu	Enter	Select ▶ Submenu
			F9	Setup Defaults
			F10	Previous Values

Figure 3- 7. Advanced Setup Menu

Table 3- 7. Advanced Menu Options

Feature	Description
Plug & Play O/S	Select Yes if you are using an operating system with Plug & Play capabilities (such as Windows 95).
Reset Configuration Data	Used to reset the Plug & Play configuration data table when new devices are added or removed, or whenever the BIOS is upgraded.
Large Disk Access Mode	Select <i>DOS</i> if your system has DOS. Select <i>Other</i> if you have another operating system, such as UNIX. A large disk is one that has more than 1024 cylinders, more than 16 heads, or more than 63 tracks per sector.

Integrated Peripherals Submenu

The Integrated Peripherals Submenu is used to configure the COM ports and the parallel ports, and enable/disable the diskette, enhanced IDE controllers, and onboard BIOS.

PhoenixBIOS Setup-Copyright 1985-95 Phoenix Technologies Ltd.	
Advanced	
Integrated Peripherals	Item Specific Help
UART1 port: [3F8, IRQ4] UART2 port: [2F8, IRQ3] UART3 port: [3E8, None] UART4 port: [2E8, None] Parallel Port: [378, IRQ7] Parallel Port Mode: [Bi-directional] Diskette controller: [Enabled] Local Bus IDE adapter: [Primary] Integrated IDE adapter: [Disabled] On-board Expansion BIOS [Disabled] ▶ 32-Pin ROM Site	<p><i>If the line item you are viewing has specific help, it will be listed here.</i></p>
F1 Help	↑↓ Select Item
ESC Exit	←→ Select Menu
-/+ Change Values	Enter Select ▶ Submenu
F9 Setup Defaults	F10 Previous Values

Figure 3- 8. Integrated Peripherals Submenu

Table 3- 8. Integrated Peripherals Submenu Options

Option	Description
UART1-4 Port	Allows the COM port address and IRQ levels to be modified or disabled.
Parallel Port	Select a unique address and interrupt request for the LPT port, or disable it. <i>Auto</i> selects the next available combination.
Parallel Mode	LPT port can be configured for <i>Bi-directional</i> or output only (<i>Standard</i>).
Diskette Controller	Enables or disables the onboard floppy disk controller.
Local Bus IDE Adapter	Enables or disables the onboard IDE controller.
Integrated IDE Adapter	Enables or disables the secondary IDE controller.
Onboard Expansion BIOS	Enables or disables the onboard expansion BIOS. The default is <i>Disabled</i> .

32-Pin ROM Site Submenu

The 32-Pin ROM Site Submenu lets you enable or disable this site, as well as specify the type of device that will occupy it if it is enabled.

PhoenixBIOS Setup-Copyright 1985-95 Phoenix Technologies Ltd.					
Advanced					
32-Pin ROM Site				Item Specific Help	
32-Pin ROM Site Type: [SRAM]				<i>If the line item you are viewing has specific help, it will be listed here.</i>	
32-Pin ROM Site Address: [Disabled]					
F1	Help	↑↓	Select Item	-/+	Change Values
F9	Setup Defaults				
ESC	Exit	←→	Select Menu	Enter	Select ▶ Submenu
F10	Previous Values				

Figure 3- 9. 32 Pin ROM Site Submenu

Table 3- 9. 32 Pin ROM Site Submenu Options

Option	Description
32-Pin ROM Site Type	Selects the type of device installed in the 32-Pin ROM site. The choices are <i>SRAM</i> or <i>Disk-On-Chip</i> . <i>SRAM</i> is the default. You can disable this feature by selecting <i>Disabled</i> in the 32-Pin ROM Site Address field.
32-Pin ROM Site Address	Disables or selects the address for the device installed in the 32-Pin ROM site. You can disable the <i>SRAM</i> or <i>DiskOnChip</i> by selecting <i>Disabled</i> . Other choices are <i>CC000h-CFFFFh (16 KB)</i> , <i>D0000h-D7FFFh (32KB)</i> , or <i>D8000h-DFFFFh (32KB)</i> . <i>Disabled</i> is the default.

Advanced Chipset Control Submenu

Use this menu to change the values in the chipset registers and optimize your system's performance.

PhoenixBIOS Setup-Copyright 1985-95 Phoenix Technologies Ltd.	
Advanced	
Advanced Chipset Control	Item Specific Help
DRAM Speed: [70ns] DMA Aliasing: [Enabled] 8-bit I/O Recovery: [4.5] 16 bit I/O Recovery: [4.5] ECC/Parity Config: [Disabled]	<i>If the line item you are viewing has specific help, it will be listed here.</i>
F1 Help ↑↓ Select Item -/+ Change Values F9 Setup Defaults ESC Exit ←→ Select Menu Enter Select ▶ Submenu F10 Previous Values	

Figure 3- 10. Advanced Chipset Control Submenu

Table 3- 10. Advanced Chipset Control Submenu Options

Option	Description
DRAM Speed	Speed of the SIMMs installed. This configures the system for maximum performance.
DMA Aliasing	Disable DMA Aliasing if a device exists on the ISA bus that uses I/O ports 90-9Fh.
8-bit I/O Recovery	Number of ISA clock cycles inserted between back-to-back I/O operations
16 bit I/O Recovery	Number of ISA clock cycles inserted between back-to-back I/O operations
ECC/Parity Config	If all memory in the system supports parity (x36), this selection enables simple parity checking or ECC mode.

Note

Leave the options in this menu in their default configurations.

Security Menu

This menu prompts you for the new system password and requires you to verify the password by entering it again. The password can be used to stop access to the setup menus or prevent unauthorized booting of the unit. The supervisor password can also be used to change the user password.

PhoenixBIOS Setup-Copyright 1985-95 Phoenix Technologies Ltd.					
Main	Advanced	Security	VMEbus	Exit	
Supervisor Password is Disabled				Item Specific Help	
User Password is Disabled				<i>If the line item you are viewing has specific help, it will be listed here.</i>	
Set Supervisor Password [Press Enter]					
Set User Password Press Enter					
Password on boot: [Disabled]					
Diskette access: [Supervisor]					
Fixed disk boot sector: [Normal]					
System backup reminder: [Disabled]					
Virus check reminder: [Disabled]					
F1 Help	↑↓	Select Item	-/+		Change Values
ESC Exit	←→	Select Menu	Enter	Select ▶ Submenu	F10 Previous Values

Figure 3- 11. Security Menu

Table 3- 11. Security Menu Options

Option	Description
Supervisor Password	Provides full access to Setup menus. You may use up to seven alphanumeric characters. This option is disabled by setting it to [CR] or <i>Nothing</i> .
Set User Password	Provides restricted access to Setup menus. It requires the prior setting of Supervisor password. You may use up to seven alphanumeric characters.
Password on Boot	If the supervisor password is set and this option is <i>Disabled</i> , BIOS assumes the user is booting.
Diskette Access	Restricts access to floppy drives to the supervisor when set to <i>Supervisor</i> . Requires setting the Supervisor password.
Fixed Disk Boot Sector	Write protects the disk boot sector to help prevent viruses.
System Backup Reminder/Virus Check Reminder	Displays a message during boot up asking if you have backed up the system or scanned it for viruses (Y/N). The message returns on each boot until you respond Y. It displays the message <i>Daily</i> (on the first boot of the day), <i>Weekly</i> (on the first boot after Sunday), or <i>Monthly</i> (on the first boot of the

Option	Description
	month). The default is <i>Disabled</i> .

VMEbus Setup Menu

Using the VMEbus Setup menus, you are able to configure the XVME-653/658 VMEbus master and slave interfaces.

This setup provides the following configurable items:

- System Controller
- Master Interface
- Slave Interface

PhoenixBIOS Setup-Copyright 1985-95 Phoenix Technologies Ltd.				
Main	Advanced	Security	VMEbus	Exit
▶ System Controller ▶ Master Interface Slave Interface: Slave 1&2 Operational Mode: [Programmable]				Item Specific Help
▶ Slave 1: [Off] ▶ Slave 2: [Off] ▶ Slave 3: [Off] ▶ Slave 4: [Off]				If the line item you are viewing has specific help, it will be listed here.
F1 Help ↑↓ Select Item -/+ Change Values F9 Setup Defaults ESC Exit ←→ Select Menu Enter Select ▶ Submenu F10 Previous Values				

Figure 3- 12. VMEbus Setup Menu

Table 3- 12. VMEbus Setup Menu Options

Option	Description
Slave 1 & 2 Operational Mode	Selecting <i>Programmable</i> allows you to configure and enable VMEbus slaves 1, 2, 3, and 4. When <i>Compatible</i> is selected, the BIOS automatically configures and enables VMEbus slaves 1 and 2. <i>Compatible</i> sets up the XVME-653/658 slave interface so that it is compatible with older Xycom Automation VME PC processor boards, which did not use the Universe chip.

System Controller Submenu

The XVME-653/658 automatically provides slot 1 system resource functions. The system resource functions are explained in the Universe manual. (Contact Tundra at www.tundra.com for a .pdf version of the Universe II manual.) This function can be disabled using jumper J1. Refer to **Jumper Settings** in Chapter 2 for more information. System resources are VMEbus Arbiter, BERR timeout, SYSCLK, and IACK daisy chain driver. These resources must be provided by the module installed in the system controller slot. The status of the XVME-653/658 system resources is reported in an un-editable field.

Note
The BERR timeout is the VMEbus error timeout value.

PhoenixBIOS Setup-Copyright 1985-95 Phoenix Technologies Ltd.					
VMEbus					
System Controller				Item Specific Help	
System Resources:	Enabled			<i>If the line item you are viewing has specific help, it will be listed here.</i>	
BERR Timeout:	[64µs]				
Arbitration Mode:	[Priority/Single]				
F1 Help	↑↓ Select Item	-/+ Change Values	F9 Setup Defaults		
ESC Exit	←→ Select Menu	Enter Select ▶ Submenu	F10 Previous Values		

Figure 3- 13. System Controller Submenu

Table 3- 13. System Controller Submenu Options

Option	Description
System Resources	Enables or disables system resources. You cannot edit this field. It is automatically detected by the board.
BERR Timeout*	Sets the VMEbus error timeout. Choices are 16µs, 32µs, 64µs, 128µs, 256µs, 512µs, 1024µs, and Disabled. The default is 64µs.
Arbitration Mode*	Sets the VMEbus arbitration mode. Choices are Priority/Single or Round Robin. Priority/Single is the default.

Note
These fields are only referenced if the board is the system controller. If it is not the system controller, the setup field values are ignored, BERR Timeout is set to 0 = Disabled, and Arbitration Mode is set to Round Robin, with an Arbitration timeout value of 0 (Disabled).

Master Interface Submenu

The VMEbus master setup lets you configure the XVME processor board’s VMEbus master interface.

Note

When the master interface setting is turned on, master image 0 is reserved for BIOS use. To avoid conflict, master images 1, 2, and 3 are available for use.

PhoenixBIOS Setup-Copyright 1985-95 Phoenix Technologies Ltd.		
VMEbus		
Master Interface	Item Specific Help	
Request Level: [Level 3] Request Mode: [Demand] Release Mode: [When Done]	<i>If the line item you are viewing has specific help, it will be listed here.</i>	
F1 Help ↑↓ Select Item -/+ Change Values F9 Setup Defaults ESC Exit ←→ Select Menu Enter Select ▶ Submenu F10 Previous Values		

Figure 3- 14. Master Interface Submenu

Table 3- 14. Master Interface Submenu Options

Option	Description
Request Level	Sets the bus request level when requesting use of the VMEbus to <i>Level 0, Level 1, Level 2, or Level 3</i> . The default is <i>Level 3</i> .
Request Mode	Sets the bus request mode. Choices are <i>Demand</i> or <i>Fair</i> . The default is <i>Demand</i> .
Release Mode	Sets the bus release mode to use when controlling the VMEbus. The default is <i>When Done</i> .

Slave Interface Submenus

The VMEbus slave setup allows configuration of the XVME processor board's VMEbus slave interfaces.

Note

When the Slave 1 & 2 Operational Mode setting is *Compatible*, slave images 0 and 1 are reserved for BIOS use. See p. 44 for more details.

PhoenixBIOS Setup-Copyright 1985-95 Phoenix Technologies Ltd.		
VMEbus		
Slave Interface		Item Specific Help
Slave 1:	[Off]	<i>If the line item you are viewing has specific help, it will be listed here.</i>
Address Modifiers:	[Data]	
	[Non-Privileged]	
Address Space:	[VMEbus Extended]	
Size:	[1MB]	
Base Address:	[AA400000]	
F1 Help	↑↓ Select Item	-/+ Change Values
ESC Exit	←→ Select Menu	Enter Select ▶ Submenu
		F9 Setup Defaults
		F10 Previous Values

Figure 3- 15. Slave Interface Submenu

Table 3- 15. Slave Interface Submenu

Option	Description
Slave 1 (or 2, 3, or 4)	Turns the slave interface <i>On</i> or <i>Off</i> . The default is <i>Off</i> . When turned off, other VME masters cannot access memory on the XVME-653/658.
Address Modifiers	Determines which type of VMEbus slave access is permitted to read or write to the XVME-653/658 dual-access DRAM. The first field determines whether the slave interface responds to <i>Data</i> access only, <i>Program</i> access only, or to <i>Both</i> program and data access. The default is <i>Data</i> . The second field determines whether the slave interface responds to <i>Supervisory</i> access only, <i>Non-Privileged</i> access only, or to <i>Both</i> supervisory and non-privileged access. The default is <i>Non-Privileged</i> .
Address Space	Determines if VME masters access the slave's dual-access memory in the VMEbus <i>Standard</i> (A24) or VMEbus <i>Extended</i> (A32) address space. The default is VMEbus <i>Extended</i> .
Slave Memory Size	Determines the amount of dual-access memory that is available to external VMEbus masters when the Slave Address Space option is set to <i>Extended</i> . The slave memory size cannot be more than the total memory size or greater than <i>16 MB</i> in <i>Standard</i> mode. The default is <i>1 MB</i> .
Slave Base Address	Sets the VMEbus address of the XVME-653/658 dual-access RAM. When the Slave Address Space option is set to VMEbus <i>Standard</i> (A24), the dual-access memory must be located on a 1 MB boundary and the upper two hex digits of the slave address are ignored. When the Slave Address Space option is set to VMEbus <i>Extended</i> (A32), the slave address must be a multiple of the slave memory size. The default is <i>AA400000</i> .

Exit Menu

This menu prompts you to exit setup.

PhoenixBIOS Setup-Copyright 1985-95 Phoenix Technologies Ltd.					
Main	Advanced	Security	VMEbus	Exit	
Save Changes & Exit Exit Without Saving Changes Get Default Values Load Previous Values Save Changes					Item Specific Help <i>If the line item you are viewing has specific help, it will be listed here.</i>
F1 Help	↑↓	Select Item	-/+	Change Values	F9 Setup Defaults
ESC Exit	←→	Select Menu	Enter	Select ▶ Submenu	F10 Previous Values

Figure 3- 16. Exit Menu

Table 3- 16. Exit Menu Options

Option	Description
Save Changes & Exit	<p>After making your selections on the Setup menus, always select either <i>Save Changes & Exit</i> or <i>Save Changes</i>. Both procedures store the selections displayed in the menus in battery-backed CMOS RAM. After you save your selections, the program displays this message:</p> <pre style="text-align: center;"> _____ Notice _____ Changes have been saved. _____ [Continue] _____ </pre> <p>If you try to exit without saving, the program asks if you want to save before exiting. The next time you boot your computer, the BIOS configures your system according to the setup selections stored in CMOS. If those values cause the system boot to fail, reboot and press F2 to enter Setup. In Setup, you can get the default values (as described below) or try to change the selections that caused the boot to fail.</p>
Exit Without Saving Changes	<p>This option exits Setup without storing any new selections you have made in CMOS. The previous settings remain in effect.</p>
Get Default Values	<p>To display the default values for all the Setup menus, select this option. The program displays this message:</p> <pre style="text-align: center;"> _____ Notice _____ Default values have been loaded. _____ [Continue] _____ </pre> <p>If during boot up, the BIOS program detects a problem in the integrity of values stored in CMOS, it displays these messages:</p> <pre style="text-align: center;"> System CMOS checksum bad - run SETUP Press <F1> to resume, <F2> to Setup </pre> <p>This means the CMOS values have been corrupted or modified incorrectly, perhaps by an application program that changes data stored in CMOS. Press F1 to resume the boot (this causes the system to be configured using the default values) or F2 to run Setup with the ROM default values already loaded into the menus. You can make other changes before saving the values to CMOS.</p>
Load Previous Values	<p>If, during a Setup session, you change your mind about changes you have made and have not yet saved the values to CMOS, you can restore the values you previously saved to CMOS. Selecting <i>Load Previous Values</i> updates all the selections and displays this message:</p> <pre style="text-align: center;"> _____ Notice _____ Previous values have been loaded. _____ [Continue] _____ </pre>
Save Changes	<p>This option saves your selections without exiting Setup. You can return to the other menus if you want to review and change your selections.</p>

BIOS Compatibility

This BIOS is IBM PC compatible with additional CMOS RAM and BIOS data areas used.

Chapter 4 – Programming

Memory Map

Table 4–1. XVME-653/658 Memory Map

Address Range	Size	Usage
FFFC0000-FFFFFFFF	256 KB	System BIOS
Top of DRAM-FFFBFFFF		Allocated to PCI bus by BIOS or operating system*
00100000-0FFFFFFF	256 MB	System DRAM
00100000-07FFFFFF	128 MB	
00100000-03FFFFFF	64 MB	
00100000-01FFFFFF	32 MB	
00100000-00FFFFFF	16 MB	
00100000-007FFFFF	8 MB	
000F0000-000FFFFF	64 KB	System BIOS
000E0000-000EFFFF	64 KB	System BIOS, Universe chip, or I/O channel memory
00D0000-00DFFFF	64 KB	Universe chip, I/O channel memory, SRAM, or <i>DiskOnChip</i>
000CC000-000CFFFF	16 KB	I/O channel memory, SRAM, or <i>DiskOnChip</i>
000C0000-000CBFFF	48 KB	VGA BIOS
000A0000-000BFFFF	128 KB	VGA DRAM memory
00000000-0009FFFF	640 KB	System DRAM

Note

The PCI devices are located at the very top of memory, just below the system BIOS.

I/O Map

Table 4-2. XVME-653/658 I/O Map

Address Range	Device
000-01F	DMA controller 1, 8237A-5 equivalent
020-021	Interrupt controller 1, 8259 equivalent
022-023	Available
025-02F	Interrupt controller 1, 8259 equivalent*
040-05F	Timer, 8254-2 equivalent
060-06F	Keyboard, 8742 equivalent
070-07F	Real-time clock, bit 7 NMI mask*
080-091	DMA page register*
93-9F	DMA page register*
0A0-0BF	Interrupt controller 2, 8259 equivalent*
0C0-0DF	DMA controller 2, 8237A-5 equivalent*
0F0-0FF	Numeric Data Processor
100	Available
101-1EF	Available
1F0-1F7	IDE controller (AT drive)
1F8-217	Available
218	XA TEMP/ABORT port
219	XA LED/BIOS port
220-232	Available
233	XA Watchdog timer port
234	XA NVRAM and <i>DiskOnChip</i> port
280-2F7	Available
2F8-2FF	Serial port 2**
378-37F	Parallel port 1**
3E0-3EF	Available
3F0-3F7	Primary floppy disk controller
3F8-3FF	Serial port 1**

Note

Reference the Intel HX PCI chip set data book for detailed information.

Note

Serial and parallel port addresses are controlled in the BIOS Setup Menu and they may be changed or disabled. Changing the setting will change the I/O location. Therefore, these addresses may be used for some applications and not for others.

IRQ Map

Table 4-3. AT-bus IRQ Map

Interrupt	Description
IRQ 0	System Timer Tick
IRQ 1	Keyboard
IRQ 2	Reserved (Programmable Interrupt Controller)
IRQ 3	COM 2
IRQ 4	COM 1
IRQ 5	Ethernet LAN Controller
IRQ 6	Floppy Disk Controller
IRQ 7	Parallel Port (LPT1)
IRQ 8	Real-Time Clock
IRQ 9	Pin 4 - PIIX3 USB Interface
IRQ 10	Onboard Reset switch
IRQ 11	Pin 1 - Universe Chip (PCI Bridge)
IRQ 12	PS/2 Mouse
IRQ 13	Reserved (Numeric Data Processor)
IRQ 14	IDE Hard Disk Controller
IRQ 15	Reserved (Secondary IDE Controller)

Note

Serial and parallel port IRQs are available if software does not use the ports or does not use the interrupt.

VME Interface

The VME interface is the Tundra Universe chip, which is a PCI bus-to-VMEbus bridge device. The XVME-653/658 implements a 32-bit PCI bus and a 32/64-bit VMEbus interface. The Universe chip configuration registers are located in a 64 KB block of PCI *memory* space. This memory location is programmable and defined by PCI configuration cycles. The Universe configuration registers should be set up using PCI interrupt calls provided by the BIOS.

For information on accessing the PCI bus, refer to the PCI BIOS Functions section later in this chapter.

Caution

The Universe II manual states that the Universe Control and Status Registers (UCSR) occupy 4 KB of internal memory. While this is true, the Universe controller decodes the entire 64 KB region and shadows the 4 KB 16 times. Contact Tundra at www.tundra.com for a .pdf version of the Universe II manual.

Note

PCI memory slave access = VMEbus master access
PCI memory master access = VMEbus slave access

System Resources

The XVME-653/658 automatically provides slot 1 system resource functions. The system resource functions are explained in the Universe manual. (Contact Tundra at www.tundra.com for a .pdf version of the Universe II manual.) This function can be disabled using jumper J1. Refer to **Jumper Settings** in Chapter 2 (pg. 12) for more information.

VMEbus Master Interface

The XVME-653/658 can act as a VMEbus master by accessing a PCI slave channel or by the DMA channel initiating a transaction. The Universe chip contains eight PCI slave images. Slave images 0 and 4 have a 4 KB resolution; the others (1-3, 5-7) have a 64 KB resolution. Slave images 0 through 3 have been implemented on the XVME-653/658. Slave images 4-7, if required, need to be implemented by the user. The VMEbus master can generate A16, A24, or A32 VMEbus cycles for each PCI slave image.

The address mode and type are programmed on a PCI slave image basis. The PCI memory address location for the VMEbus master cycle is specified by the Base and Bound address. The VME address is calculated by adding the Base address to the Translation Offset address. All PCI slave images are located in the PCI bus memory space.

All VMEbus master cycles are byte-swapped by the Universe chip to maintain address coherency. For more information on the Xycom Automation software selectable byte-swapping hardware on the XVME-658 and the XVME-653/31x modules, refer to pg. 62.

Caution

PCI slave images mapped to a system DRAM area will access the system DRAM, not the PCI slave image. Also, the Universe configuration register has a higher priority than the PCI slave images. As a result, if the PCI slave image and the Universe configuration registers are mapped into the same memory area, the configuration registers will take precedence.

VMEbus Slave Interface

The XVME-653/658 can act as a VMEbus slave by configuring the VMEbus slave images. There are eight PCI slave images. Slave images 0 and 4 have a 4 KB resolution; the others (1-3, 5-7) have a 64 KB resolution. Slave images 0 through 3 have been implemented on the XVME-653/658. Slave images 4-7, if required, need to be implemented by the user. The slave can respond to A16, A24, or A32 VMEbus cycles for each VMEbus slave image.

The address mode and type are programmed on a VMEbus slave image basis. The VMEbus memory address location for the VMEbus slave cycle is specified by the Base and Bound address. The PCI address is calculated by adding the Base address to the Translation offset address.

The XVME-653/658 DRAM memory is based on the PC architecture and is not contiguous. The VMEbus slave images may be set up to allow this DRAM to appear as one contiguous block.

In Compatible Mode, the first VMEbus slave image will have the Base and Bound register set to 640 KB by the BIOS. For example:

VMEbus Slave Image 0 BS= 0000000h BD= A0000h TO = 0000000h

The second VMEbus slave image will have the Base register set to be contiguous with the Bound register from the first VMEbus Slave image by the BIOS. The Bound register is limited by the total XVME-653/658 DRAM. The Translation Offset register is offset by 384 KB, which is equivalent to the A0000h-FFFFFh range on the XVME-653/658 board. For example:

VMEbus Slave Image 1 BS=A0000h BD= 400000h TO = 060000h

Mapping defined by the PC architecture can be overcome if the VMEbus Slave image window is always configured with a 1 MB Translation Offset. From a user and software standpoint, this is desirable because the interrupt vector table, system parameters, and communication buffers (keyboard) are placed in low DRAM. This provides more system protection.

Caution

When setting up slave images, the address and other parameters should be set first. Only after the VMEbus slave image is set up correctly should the VMEbus slave image be enabled. If a slave image is going to be remapped, disable the slave image first, and then reset the address. After the image is configured correctly, re-enable the image.

The VMEbus slave cycle becomes a master cycle on the PCI bus. The PCI bus arbiter is the TSC chip. It arbitrates between the various PCI masters, the Pentium CPU, and the Local bus IDE bus mastering controller. Because the VMEbus cannot be retried, all VMEbus slave cycles must be allowed to be processed. This becomes a problem when a PCI cycle to a PCI slave image is in progress while a VMEbus slave cycle to the onboard DRAM is in progress. The PCI cycle will not give up the PCI bus and the VMEbus slave cycle will not give up the VMEbus, causing the XVME-653/658 to become deadlocked. If the XVME-653/658 is to be used as a master and a slave at the same time, the VMEbus master cycles must obtain the VMEbus prior to initiating VMEbus cycles.

All VMEbus slave interface cycles are byte-swapped to maintain address coherency. For more information on the Xycom Automation software selectable byte-swapping hardware on the XVME-658 and the XVME-653/31x modules, refer to pg. 62.

VMEbus Interrupt Handling

The XVME-653/658 can service VME IRQ[7:1]. A register in the Universe chip enables the interrupt levels that will be serviced by the XVME-653/658. When a VMEbus IRQ is asserted, the Universe requests the VMEbus and generates an IACK cycle. Once the IACK cycle is complete, a PCI bus interrupt is generated to allow the proper Interrupt Service Routine (ISR) to be executed. The Universe connects to all four PCI bus interrupts. These interrupts may be shared by other PCI bus devices. The BIOS maps the PCI bus interrupts to the AT-bus interrupt controllers on IRQ11.

Because the PCI devices share interrupt lines, all ISR routines must be prepared to chain the interrupt vector to allow the other devices to be serviced.

Note

All PCI devices on the XVME-653/658 are routed through IRQ11.

Caution

IRQ10 is defined for the Abort toggle switch.

VMEbus Interrupt Generation

The XVME-653/658 can generate VMEbus interrupts on all seven levels. There is a unique STATUS/ID associated with each level. Upper bits are programmed in the STATUS/ID register. The lowest bit is cleared if the source of the interrupt is a software interrupt, and set for all other interrupt sources. Consult the Universe User's Manual for a more in-depth explanation.

VMEbus Reset Options

When the front panel **Reset** switch is toggled, the XVME-653/658 can perform the following reset options:

1. Reset the VME backplane only.

2. Reset the XVME-653/658 CPU only.
3. Reset both.
4. Reset neither.

See **Switch Settings** on pg. 13 for information on how to configure the **Reset** options.

PCI BIOS Functions

Special PCI BIOS functions provide a software interface to the Universe chip, providing the PCI-to-VMEbus interface. These PCI BIOS functions are invoked using function and subfunction codes. A user sets up the host processor registers for the function and subfunction desired and calls the PCI BIOS software. The PCI BIOS function code is B1h. Status is returned using the Carry flag ([CF]) and registers specific to the subfunction invoked.

Access to the PCI BIOS special functions for 16-bit callers is provided through interrupt 1Ah. Thirty-two bit (i.e., protect mode) access is provided by calling through a 32-bit protect mode entry point.

Calling Conventions

The PCI BIOS functions preserve all registers and flags except those used for return parameters. The Carry Flag [CF] will be altered as shown to indicate completion status. The calling routine will be returned to with the interrupt flag unmodified and interrupts will not be enabled during function execution. These routines, which are re-entrant, require 1024 bytes of stack space and the stack segment must be the same size (i.e., 16- or 32-bit) as the code segment. The PCI BIOS provides a 16-bit real and protect mode interface and a 32-bit protect mode interface.

16-Bit Interface

The 16-bit interface is provided through the Int 1Ah software interrupt. The PCI BIOS Int 1Ah interface operates in either real mode, virtual-86 mode, or 16:16 protect mode. The Int 1Ah entry point supports 16-bit code only.

32-Bit Interface

The protected mode interface supports 32-bit protect mode callers. The protected mode PCI BIOS interface is accessed by calling through a protected mode entry point in the PCI BIOS. The entry point and information needed for building the segment descriptors are provided by the BIOS32 Service Directory. Thirty-two bit callers invoke the PCI BIOS routines using CALL FAR.

The BIOS32 Service Directory is implemented in the BIOS in a contiguous 16-byte data structure, beginning on a 16-byte boundary somewhere in the physical address range 0E0000h-0FFFFFFh. The address range should be scanned for the following valid, checksummed data structure containing the following fields:

Table 4-4. BIOS32 Service Table

Offset	Size	Description
0	4 bytes	Signature string in ASCII. The string is <code>_32_</code> . This puts an underscore at offset 0, a 3 at offset 1, a 2 at offset 2, and another underscore at offset 3.
4	4 bytes	Entry point for the BIOS32 Service Directory. This is a 32-bit physical address.
8	1 byte	Revision level.
9	1 byte	Length of the data structure in 16-byte increments. (This data structure is 16 bytes long, so this field contains 01h.)
0Ah	1 byte	Checksum. This field is the checksum of the complete data structure. The sum of all bytes must add up to 0.
0Bh	5 bytes	Reserved. Must be zero.

The BIOS32 Service Directory is accessed by doing a FAR CALL to the entry point obtained from the Service data structure. There are several requirements about the calling environment that must be met. The CS code segment selector and the DS data segment selector must be set up to encompass the physical page holding the entry point as well as the immediately following physical page. They must also have the same base. The SS stack segment selector must be 32-bit and provide at least 1 KB of stack space. The calling environment must also allow access to I/O space.

The BIOS32 Service Directory provides a single function call to locate the PCI BIOS service. All parameters to the function are passed in registers. Parameter descriptions are provided below. Three values are returned by the call. The first is the base physical address of the PCI BIOS service, the second is the length of the service, and the third is the entry point to the service encoded as an offset from the base. The first and second values can be used to build the code segment selector and data segment selector for accessing the service.

ENTRY:

[EAX] Service Identifier = "\$PCI" (049435024h)

[EBX] Set to Zero

EXIT:

[AL] Return Code:

00h = SUCCESSFUL

80h = SERVICE_IDENTIFIER_NOT_FOUND

81h = INVALID VALUE IN [BL]

[EBX] Physical address of the base of the PCI BIOS service

[ECX] Length of the PCI BIOS service

[EDX] Entry point into the PCI BIOS Service. This is an offset from the base provided in [EBX].

PCI BIOS Function Calls

The available function calls are used to identify the location of resources and to access configuration space of the VMEbus interface. Special functions allow the reading and writing of individual bytes, words, and dwords in the configuration space.

PCI BIOS routines (for both 16- and 32-bit callers) must be invoked with appropriate privilege so that interrupts can be enabled/disabled and the routines can access I/O space.

Locating the Universe Chip

This function returns the location (bus number) of the Universe chip providing the PCI interface to the VMEbus.

ENTRY:

[AH] BIOS_FUNCTION_ID = B1h
[AL] BIOS_SUBFUNCTION_ID = 02h
[CX] Device ID = 0
[DX] Vendor ID = 10E3h
[SI] Index = 0

EXIT:

[BH] Bus Number (0-255)
[BL] Device Number in upper 5 bits
Function Number is bottom 3 bits
[AH] Return Code:
00h = SUCCESSFUL
86h = DEVICE_NOT_FOUND
83h = BAD_VENDOR_ID
[CF] Completion Status, set = error, reset = success

Read Configuration Byte

This function reads individual bytes from the configuration space of the VMEbus interface.

ENTRY:

- [AH] BIOS_FUNCTION_ID = B1h
- [AL] BIOS_SUBFUNCTION_ID = 08h
- [BH] Bus Number (0-255)
- [BL] Device Number in upper 5 bits
Function Number is bottom 3 bits
- [DI] Register Number (0...255)

EXIT:

- [CL] Byte Read
- [AH] Return Code:
00h = SUCCESSFUL
87h = BAD_REGISTER_NUMBER
- [CF] Completion Status, set = error, reset = success

Read Configuration Word

This function reads individual words from the configuration space of the VMEbus interface. The Register Number parameter must be a multiple of two (i.e., bit 0 must be set to 0).

ENTRY:

- [AH] BIOS_FUNCTION_ID = B1h
- [AL] BIOS_SUBFUNCTION_ID = 09h
- [BH] Bus Number (0-255)
- [BL] Device Number in upper 5 bits
Function Number is bottom 3 bits
- [DI] Register Number (0, 2, 4, ...254)

EXIT:

- [CL] Word Read
- [AH] Return Code:
00h = SUCCESSFUL
87h = BAD_REGISTER_NUMBER
- [CF] Completion Status, set = error, reset = success

Read Configuration Dword

This function reads individual dwords from the configuration space of the VMEbus interface. The Register Number parameter must be a multiple of four (i.e., bits 0 and 1 must be set to 0).

ENTRY:

[AH] BIOS_FUNCTION_ID = B1h
 [AL] BIOS_SUBFUNCTION_ID = 0Ah
 [BH] Bus Number (0-255)
 [BL] Device Number in upper 5 bits
 Function Number is bottom 3 bits
 [DI] Register Number (0, 4, 8, ...252)

EXIT:

[ECX] Dword Read
 [AH] Return Code:
 00h = SUCCESSFUL
 87h = BAD_REGISTER_NUMBER
 [CF] Completion Status, set = error, reset = success

Write Configuration Byte

This function writes individual bytes from the configuration space of the VMEbus interface.

ENTRY:

[AH] BIOS_FUNCTION_ID = B1h
 [AL] BIOS_SUBFUNCTION_ID = 0Bh
 [BH] Bus Number (0-255)
 [BL] Device Number in upper 5 bits
 Function Number is bottom 3 bits
 [DI] Register Number (0...255)
 [CL] Byte Value to Write

EXIT:

[AH] Return Code:
 00h = SUCCESSFUL
 87h = BAD_REGISTER_NUMBER
 [CF] Completion Status, set = error, reset = success

Write Configuration Word

This function writes individual words from the configuration space of the VMEbus interface. The Register Number parameter must be a multiple of two (i.e., bit 0 must be set to 0).

ENTRY:

[AH] BIOS_FUNCTION_ID = B1h
 [AL] BIOS_SUBFUNCTION_ID = 0Ch
 [BH] Bus Number (0-255)
 [BL] Device Number in upper 5 bits
 Function Number is bottom 3 bits
 [DI] Register Number (0, 2, 4, ...254)
 [CX] Word Value to Write

EXIT:

[AH] Return Code:
 00h = SUCCESSFUL
 87h = BAD_REGISTER_NUMBER
 [CF] Completion Status, set = error, reset = success

Write Configuration Dword

This function writes individual dwords from the configuration space of the VMEbus interface. The Register Number parameter must be a multiple of four (i.e., bits 0 and 1 must be set to 0).

ENTRY:

[AH] BIOS_FUNCTION_ID = B1h
 [AL] BIOS_SUBFUNCTION_ID = 0Dh
 [BH] Bus Number (0-255)
 [BL] Device Number in upper 5 bits
 Function Number is bottom 3 bits
 [DI] Register Number (0, 4, 8, ...252)
 [ECX] Dword Value to Write

EXIT:

[AH] Return Code:
 00h = SUCCESSFUL
 87h = BAD_REGISTER_NUMBER
 [CF] Completion Status, set = error, reset = success

Software-Selectable Byte-Swapping Hardware

Software-selectable byte-swapping hardware is integrated into all XVME-658 and XVME-653/31x boards (see Table 1-3) to allow for the difference between the Intel and Motorola byte-ordering schemes, allowing easy communication over the VMEbus. The byte-swapping package incorporates several buffers either to pass data straight through or to swap the data bytes as they are passed through.

Byte-Ordering Schemes

The Motorola family of processors stores data with the least significant byte located at the highest address and the most significant byte at the lowest address. This is referred to as a big-endian bus and is the VMEbus standard. The Intel family of processors—which includes the AMD-K6 processors as well as the Intel Pentium processors—stores data in the opposite way, with the least significant byte located at the lowest address and the most significant byte located at the highest address. This is referred to as a little-endian (PCI) bus. This fundamental difference is illustrated in the figure below, which shows a 32-bit quantity stored by both architectures, starting at address M .

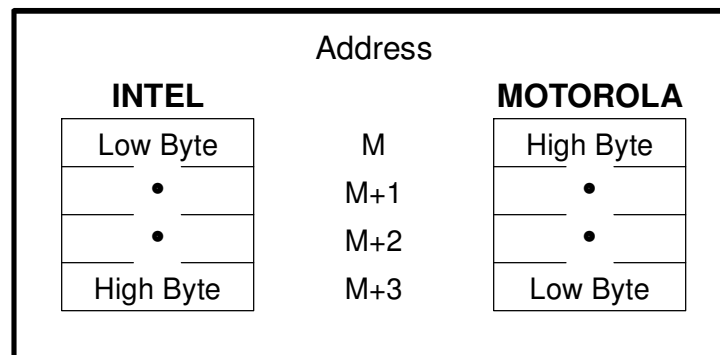

Figure 4-1. Byte Ordering Schemes

Note

The two architectures differ only in the way in which they store data into memory, not in the way in which they place data on the shared data bus.

The XVME-653/658 contains a Universe chip that performs address-invariant translation between the PCI bus (Intel architecture) and the VMEbus (Motorola architecture), and byte-swapping hardware to reverse the Universe chip byte-lane swapping. (Contact Tundra at www.tundra.com for a .pdf version of the Universe II manual.) Figure 4-2 shows address-invariant translation between a PCI bus and a VMEbus.

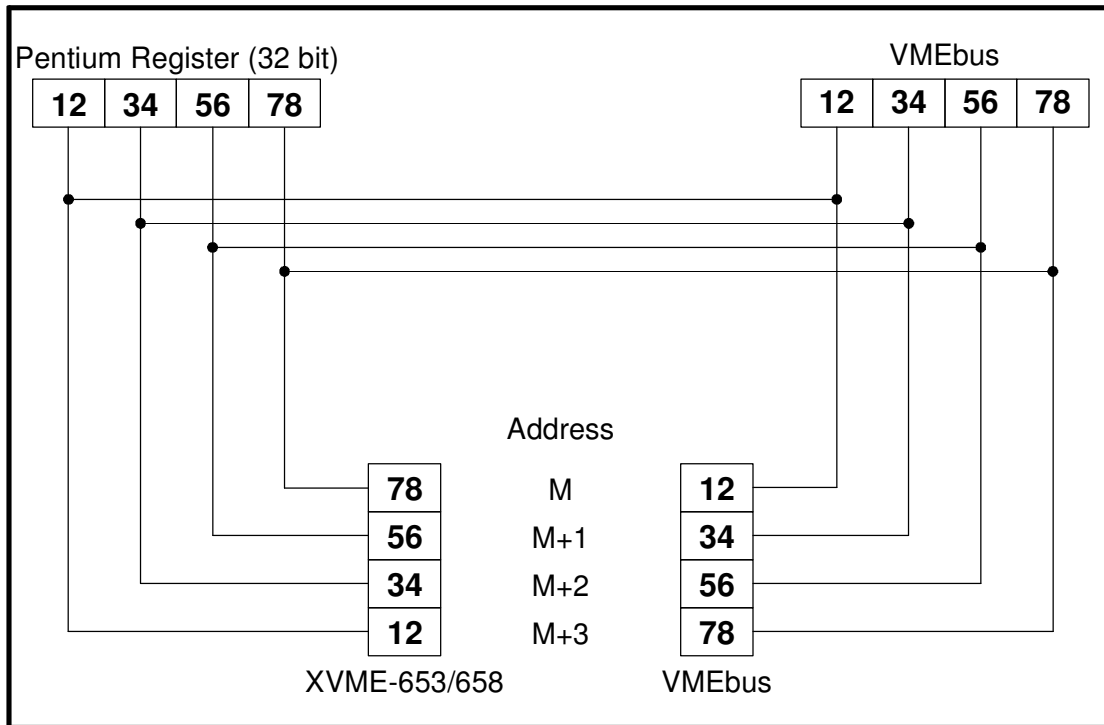

Figure 4-2. Address-Invariant Translation

Notice that the internal data storage scheme for the PCI (Intel) bus is different from that of the VME (Motorola) bus. For example, the byte 78 (the least significant byte) is stored at location M on the PCI machine while the byte 78 is stored at the location $M+3$ on the VMEbus machine. Therefore, the data bus connections between the architectures must be mapped correctly.

Numeric Consistency

Numeric consistency, or data consistency, refers to communications between the XVME-653/658 and the VMEbus in which the byte-ordering scheme described above is maintained during the transfer of a 16-bit or 32-bit quantity. Numeric consistency is achieved by setting the XVME-653/658 buffers to pass data straight through, which allows the Universe chip to perform address-invariant byte-lane swapping. Numeric consistency is desirable for transferring integer data, floating-point data, pointers, etc. Consider the long word value **12345678h** stored at address *M* by both the XVME-653/658 and the VMEbus, as shown in Figure 4-3.

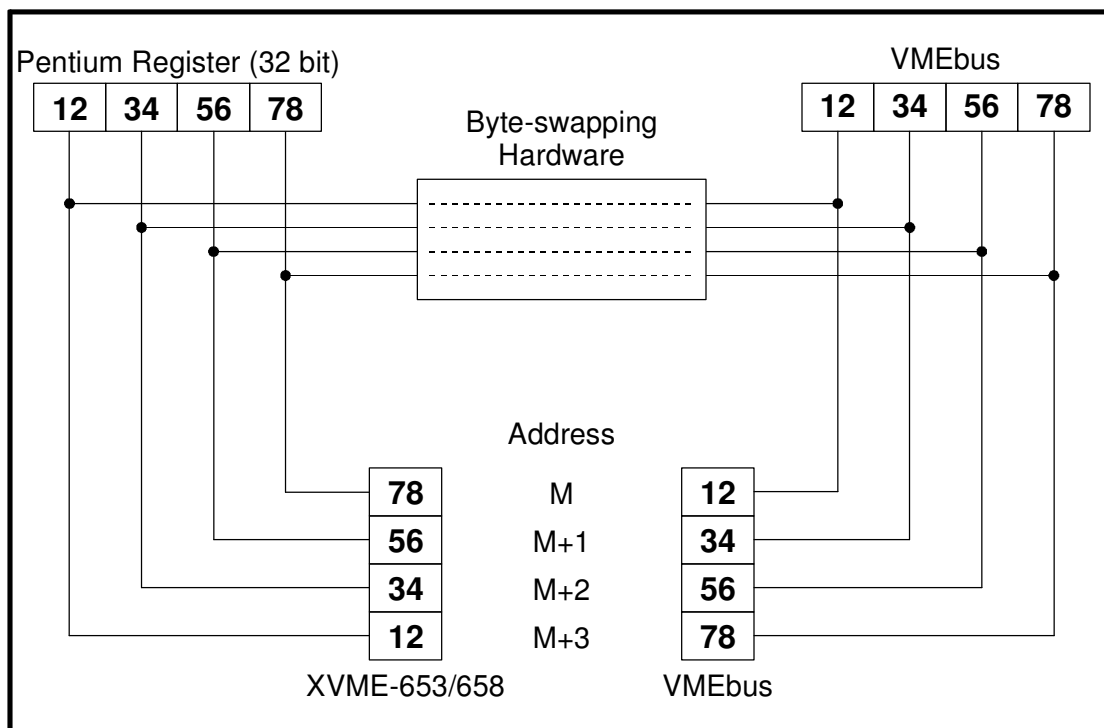

Figure 4-3. Maintaining Numeric Consistency

Due to the Universe chip, the data must be passed straight through the byte-swapping hardware. To maintain numeric consistency, enable the straight-through buffers by setting bits 6 and 7 of the NVRAM and DiskOnChip Port (Register 234h) both to 0 (same as non-byte swap board) – see p. 16. That is, hardware byte swapping is disabled, so tundra data invariance is active.

Note

With the straight-through buffers enabled, the XVME-653/658 does not support unaligned transfers. Sixteen-bit or 32-bit transfers must have an even address.

Address Consistency

Address consistency, or address coherency, refers to communications between the XVME-653/658 and the VMEbus in which both architectures' addresses are the same for each byte. In other words, the XVME-653/658 and the VMEbus memory images appear the same. Address consistency is desirable for byte-oriented data such as strings or video image data. Consider the example of transferring the string *Text* to the VMEbus memory using a 32-bit transfer in Figure 4-4.

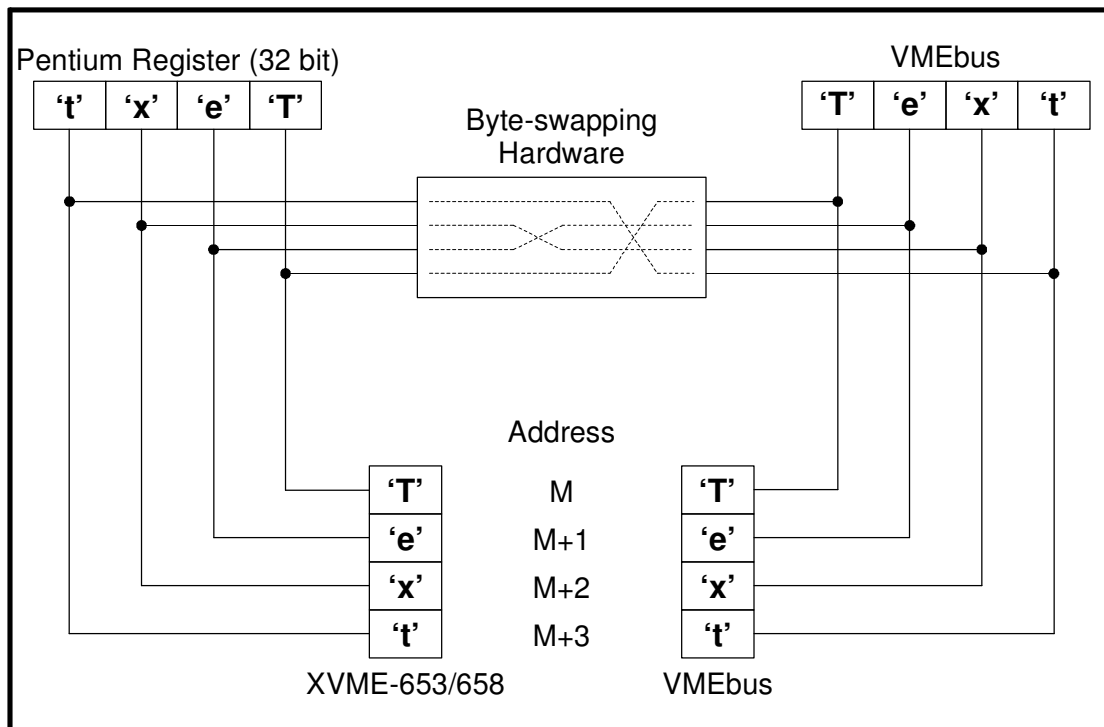

Figure 4-4. Maintaining Address Consistency

Notice that the data byte at each address is identical. To achieve this, the data bytes need to be swapped as they are passed from the PCI bus to the VMEbus. To maintain address consistency, enable the byte-swapping buffers by setting bits 6 and 7 of the NVRAM and DiskOnChip Port (Register 234h) both to 1 – see p. 16. That is, hardware byte swapping is enabled, so tundra data invariance is neutralized.

Chapter 5 – XVME-973/1 Drive Adapter Module

The XVME-973/1 Drive Adapter Module is used to connect an external hard and floppy drive to your XVME-653/658 module. It has a single edge connector, labeled P2 that connects to the P2 backplane connector on the rear of the VME chassis. Figure 5–1 illustrates how to connect the XVME-973/1 P2 connector to the VME chassis backplane P2 connector.

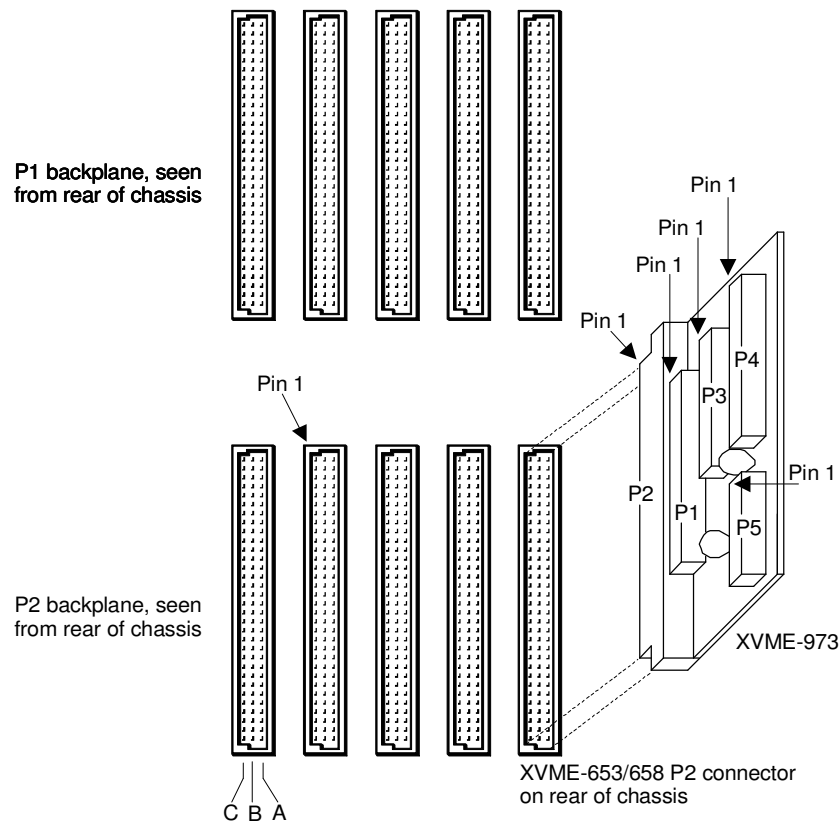

Figure 5–1. XVME-973/1 Installation

The XVME-973/1 module has four connectors on it for the connection of up to two IDE hard drives and one 3.5" floppy drive. Pinouts for all of the connectors are given in this chapter.

The P3 connector connects a single 3.5" floppy drive and the P5 connector connects a single of 3.5" floppy drive of the type found in many laptop computers. Since both of these connectors are routed to the same signal lines on the P2 connector, only one may be used at a time.

Similarly, the P1 connector connects up to two standard 3.5" hard drives and the P4 connector connects up to two 2.5" hard drives. Both of these connectors also use the same P2 connector signal lines, so only one may be used at a time.

The XVME-973/1 is shipped with cables for the P1 and the P3 connectors. The pinouts in this chapter may be used as references to make cables for the P2 and P4 connectors.

Connectors

This section describes the pinouts for each of the five connectors on the XVME-973/1.

P1 Connector

The P1 connector connects up to two 3.5" hard drives. Power for the drives is *not* supplied by the XVME-973/1.

Table 5-1. XVME-973/1 P1 Connector Pinout

Pin	Signal	Pin	Signal
1	HDRESET*	21	HDRQ
2	GND	22	GND
3	HD7	23	DIOW*
4	HD8	24	GND
5	HD6	25	DIOR*
6	HD9	26	GND
7	HD5	27	IORDY
8	HD10	28	ALE
9	HD4	29	HDACK*
10	HD11	30	GND
11	HD3	31	IRQ14
12	HD12	32	IOCS16*
13	HD2	33	DA1
14	HD13	34	NC
15	HD1	35	DA0
16	HD14	36	DA2
17	HD0	37	CS1P*
18	HD15	38	CS3P*
19	GND	39	IDEATP*
20	KEY (NC)	40	GND

Caution

The IDE controller supports enhanced PIO modes, which reduce the cycle times for 16-bit data transfers to the hard drive. Check with your drive manual to see if the drive you are using supports these modes. The higher the PIO mode, the shorter the cycle time. As the IDE cable length increases, this reduced cycle time can lead to erratic operation. As a result, it is in your best interest to keep the IDE cable as short as possible.

The PIO modes are selected in the BIOS setup (see pg. 32). The Autoconfig will attempt to classify the connected drive if the drive

supports the auto ID command. If you experience problems, change the **Transfer Mode:** to *Standard*.

Caution

The total cable length must not exceed 18 inches. Also, if two drives are connected, they must be no more than six inches apart.

P2 Connector

The XVME-973/1 P2 connector connects directly to the XVME-653/658 P2 connector through the VME chassis backplane.

Table 5-2. XVME-973/1 P2 Connector Pinout

Pin	A	B	C
1	RES	+5V	HDRSTDRV*
2	RES	GND	HD0
3	RES	RES	HD1
4	RES	RES	HD2
5	RES	RES	HD3
6	RES	RES	HD4
7	RES	RES	HD5
8	RES	RES	HD6
9	RES	RES	HD7
10	RES	RES	HD8
11	RES	RES	HD9
12	RES	GND	HD10
13	RES	+5V	HD11
14	RES	RES	HD12
15	RES	RES	HD13
16	RES	RES	HD14
17	RES	RES	HD15
18	RES	RES	GND
19	GND	RES	DIOW*
20	FRWC*	RES	DIOR*
21	IDX*	RES	IORDY
22	MO1*	GND	ALE
23	HDRQ	RES	IRQ14
24	FDS1*	RES	IOCS16*
25	HDACK*	RES	DA0
26	FDIRC*	RES	DA1
27	FSTEP*	RES	DA2
28	FWD*	RES	CS1P*
29	FWE*	RES	CS3P*

Pin	A	B	C
30	FTK0*	RES	IDEATP*
31	FWP*	GND	FHS*
32	FRDD*	+5V	DCHG*

P3 Connector

P3 connects a single 3.5" floppy drive. Only one drive is supported. Power for this drive is *not* supplied by the XVME-973/1.

Table 5-3. XVME-973/1 P3 Connector Pinout

Pin	Signal	Pin	Signal
1	GND	18	FDIRC*
2	FRWC*	19	GND
3	GND	20	FSTEP*
4	NC	21	GND
5	KEY (NC)	22	FWD*
6	NC	23	GND
7	GND	24	FWE*
8	IDX*	25	GND
9	GND	26	FTK0*
10	MO1*	27	GND
11	GND	28	FWP*
12	NC	29	GND
13	GND	30	FRDD*
14	FDS1*	31	GND
15	GND	32	FHS*
16	NC	33	GND
17	GND	34	DCHG*

P4 Connector

P4 connects up to two 2.5" hard drives. Power for the drives is supplied by the connector.

Table 5-4. XVME-973/1 P4 Connector Pinout

Pin	Signal	Pin	Signal
1	HDRSTDRV*	23	DIOW*
2	GND	24	GND
3	HD7	25	DIOR*
4	HD8	26	GND
5	HD6	27	IORDY
6	HD9	28	ALE
7	HD5	29	HDACK*
8	HD10	30	GND
9	HD4	31	IRQ14
10	HD11	32	IOCS16*
11	HD3	33	DA1
12	HD12	34	NC
13	HD2	35	DA0
14	HD13	36	DA2
15	HD1	37	CS1P*
16	HD14	38	CS3P*
17	HD0	39	IDEATP*
18	HD15	40	GND
19	GND	41	+5V
20	NC	42	+5V
21	HDRQ	43	GND
22	GND	44	NC

Caution

The IDE controller supports enhanced PIO modes, which reduce the cycle times for 16-bit data transfers to the hard drive. Check with your drive manual to see if the drive you are using supports these modes. The higher the PIO mode, the shorter the cycle time. As the IDE cable length increases, this reduced cycle time can lead to erratic operation. As a result, it is in your best interest to keep the IDE cable as short as possible.

The PIO modes are selected in the BIOS setup (see pg. 32). The Autoconfig will attempt to classify the connected drive if the drive supports the auto ID command. If you experience problems, change the **Transfer Mode:** to *Standard*.

Caution

The total cable length must not exceed 18 inches. If two drives are connected, they must be no more than six inches apart.

P5 Connector

P5 connects a single 3.5" floppy drive. Power for this drive is supplied by the connector.

Table 5-5. XVME-973/1 P5 Connector Pinout

Pin	Signal	Pin	Signal
1	+5V	14	FSTEP*
2	IDX*	15	GND
3	+5V	16	FWD*
4	FDS1*	17	GND
5	+5V	18	FWE*
6	DCHG*	19	GND
7	NC	20	FTKO*
8	NC	21	GND
9	NC	22	FWP*
10	MO1*	23	GND
11	NC	24	FRDD*
12	FDIRC*	25	GND
13	NC	26	FHS*

Appendix A – DRAM SIMM Installation

The XVME-653/658 has two 72-pin single inline memory module (SIMM) sites in which memory is inserted. Due to the CPU speed, DRAM access time should be 70 ns or less, and must be 60 ns to run with the zero wait states.

The XVME-653/658 supports 32, 64, 128, and 256 MB of DRAM. You can use 4Mx32, 8Mx32, 16Mx32, and 32Mx32 DRAM SIMM sizes. Table A- 1 lists the combinations needed for the memory configurations. (The P number is silk-screened on the front of the board.) Figure A- 1 illustrates DRAM installation.

Table A- 1. DRAM SIMM Combinations

Memory	SIMM Site P5	SIMM Site P6
32 MB	4M x 32	4M x 32
64 MB	8M x 32	8M x 32
128 MB	16M x 32	16M x 32
256 MB	32M x 32	32M x 32

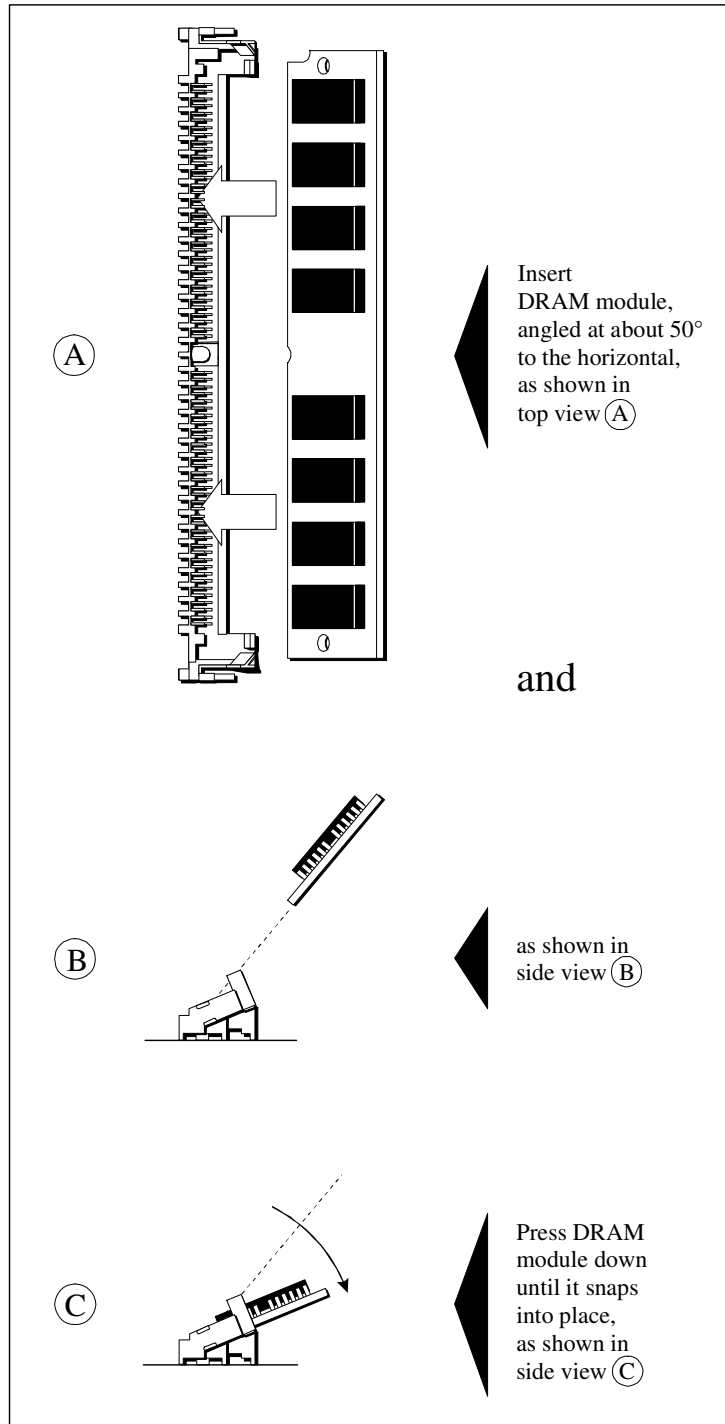

Figure A-1. DRAM Installation

To remove SIMM, pull outward on the metal tabs while lifting the end. Loosen one side, then the other.

Tables A-2 through A-5 list recommended DRAM SIMM manufacturers along with part numbers. All recommended DRAM is Fast Page mode with Extended Data Out (EDO).

Table A- 2. 4M x 32 Part Numbers

Manufacturer	Part Number
Samsung	KMM5324004BSW-6
Viking Components	VE432-416-60TS
Advantage Memory	E432-4X4-66T
AVED	AVED4E322SSM4-604
Xycom Automation	104302

Table A- 3. 8M x 32 Part Numbers

Manufacturer	Part Number
Samsung	KMM5328004BSW-6
Viking Components	VE832-416-60TS
Advantage Memory	E832-4X4-66T
Viking Components	VA8322U2EN5-XC03
AVED	AVED8E322SSM4-604
Xycom Automation	106054

Table A- 4. 16M x 32 Part Numbers

Manufacturer	Part Number
Approved Memory	AM64/56605
Xycom Automation	123514

Table A- 5. 32M x 32 Part Numbers

Manufacturer	Part Number
Advantage Memory Corp.	E3232-16X4-66TRE
Xycom Automation	138802

Appendix B – Drawings

This appendix contains the board assembly drawings (top view) for the XVME-653/658. Figure B-1 is the assembly drawing for the XVME-658 and the XVME-653/31x modules, both of which have the byte-swapping hardware. Figure B-2 is the assembly drawing for the XVME-653/30x module, which doesn't have the byte-swapping hardware.

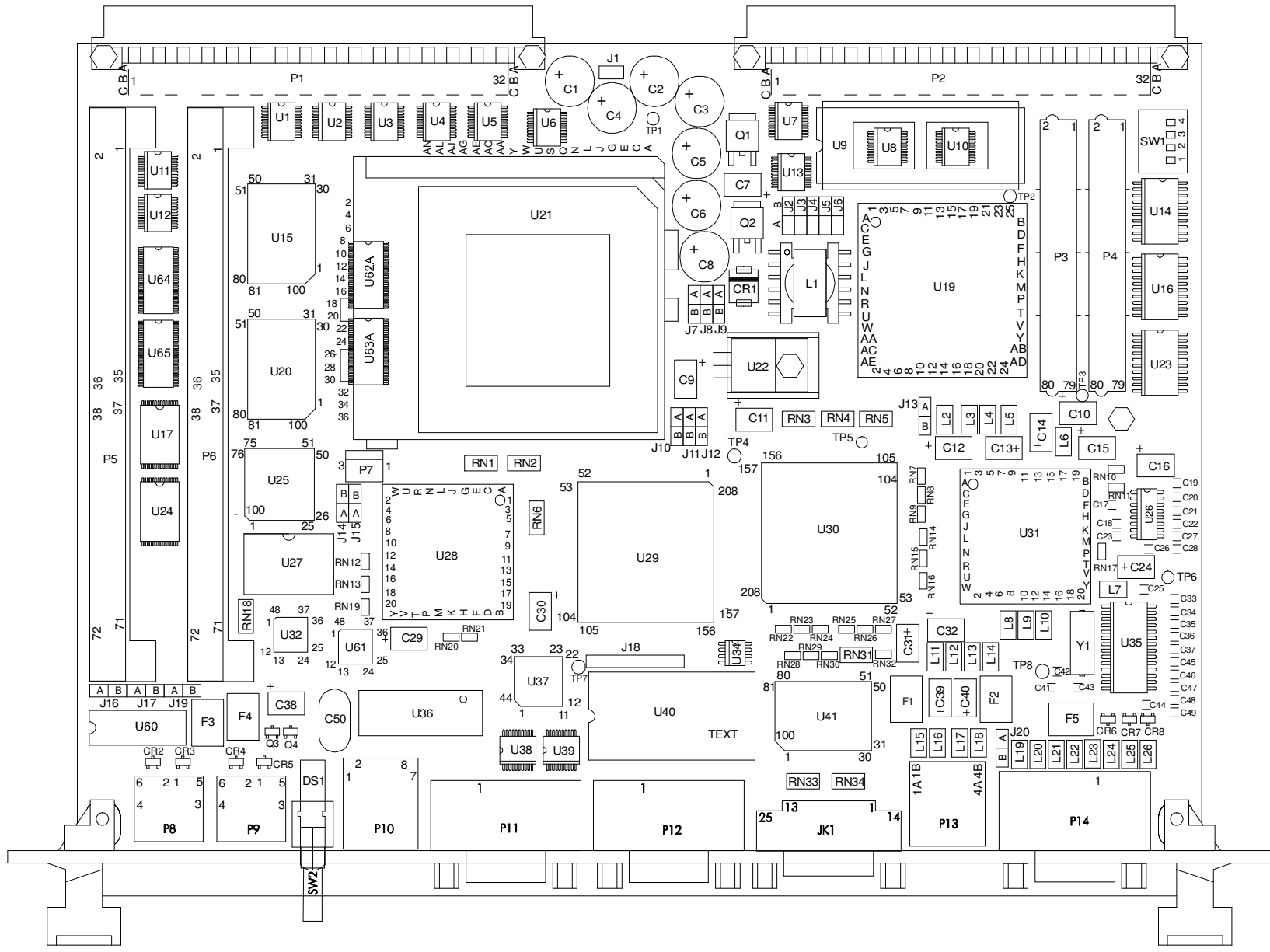

Figure B-1. Assembly Drawing for XVME-658 and XVME-653/31x

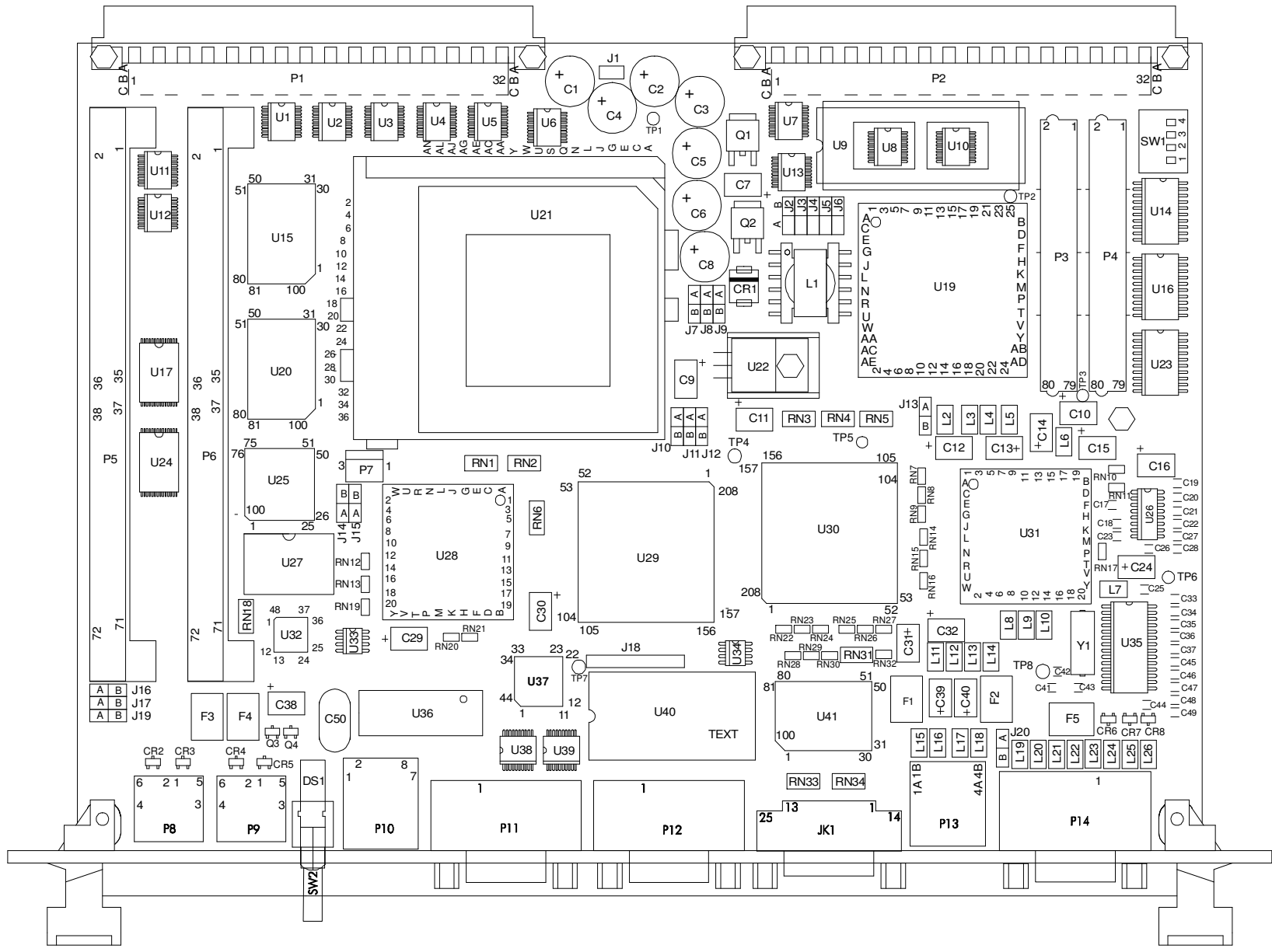

Figure B-2. Assembly Drawing for XVME-653/30x

Index

Abort toggle switch.....	54
Abort/Clear CMOS port	13
address, PCI	53
Advanced Menu, BIOS setup	37
assembly drawing.....	75, 76
auxiliary connector	18
backplane, installing the XVME-653 into	23
BIOS compatibility	48
BIOS menus	
Advanced Menu	37
32-Pin ROM Site Sub-menu	39
Advanced Chipset Control Sub-menu	40
Integrated Peripherals Sub-menu.	38
Exit Menu.....	47
general navigation information	28
Main Setup Menu.....	29
Boot Sequence Sub-menu	35
IDE Adapter 0 Master and Slave Sub-	
menu.....	31
Memory Shadow Sub-menu.....	34
Numlock Sub-menu	36
Memory Cache Sub-menu.....	33
Security Menu	41
VMEbus Setup menu	42
Master Interface sub-menu	45
Slave Interface sub-menus	46
System Controller sub-menu.....	43
BIOS32 Service Directory	55
block diagram.....	6
bus speed jumper settings	12
byte-swapping.....	9, 15, 61, 63, 64
cache	33
calling conventions, PCI BIOS functions .	55
COM port.....	<i>See</i> serial ports
compatibility, BIOS	48
compliance, VMEbus	8
connectors	
auxiliary.....	18
keyboard port.....	17
location.....	10
parallel port	16
RJ-45 10/100 Base-T.....	26
serial ports	16
Univeral Serial Bus (USB).....	17
VGA	17
VMEbus	19
interboard connector 1 (P4).....	21
interboard connector 2 (P3).....	22
XVME-973/1	
P1	66
P2	67
P3	68
P4	69
P5	70
controllers	
Ethernet	2
IDE	2
video	2
CPU	2
speed	8
CPU configuration jumper settings	11
CPU core voltage jumper settings	11
CPU voltage plane configuration jumper	
settings.....	11
<i>DiskOnChip</i>	4, 9, 10, 26, 39
DRAM	3
installation.....	71
module combinations	71
part numbers.....	73
drivers, loading Ethernet	26
drives	
floppy	5, 68, 70
hard	5, 66, 69
environmental specifications	7
Ethernet controller.....	2
Ethernet driver, loading	26
expansion	
PC/104	3
PCI	3
PCM	3
short ISA	3
external cache	4
features, XVME-653/658	1
Flash BIOS	4
floppy drive	5
front panel, XVME-653/658	25
hard drive.....	5, 31
hardware specifications	8

humidity specifications	7
I/O map	50
IDE controller	2
installation	
DRAM	71
XVME-653	23
XVME-973/1	65
interboard connector 1	21
interboard connector 2	22
interrupt configuration	38
interrupt generation, VMEbus	54
interrupt handling	
PCI bus	54
VMEbus	54
interrupt map	51
IRQ10	54
jumper locations	10
jumper settings	11
bus speed	12
CPU configuration	11
CPU core voltage	11
CPU voltage plane configuration	11
J1	43, 52
memory	12
keyboard interface	5
keyboard port connector	17
LED/BIOS port	14
memory jumper settings	12
memory map	49
memory, DRAM	3
memory, ECC or parity	3, 40
memory, EDO	3, 73
memory, fast page mode	3, 73
module features	1
NVRAM and DiskOnChip port	15
P1 connector, XVME-973/1	66
P2 connector, XVME-973/1	67
P3 connector, XVME-973/1	68
P4 connector, XVME-973/1	69
P5 connector, XVME-973/1	70
parallel port	4
parallel port connector	16
passwords	41
PCI address	53
PCI BIOS	
16-bit interface	55
32-bit interface	55
function calling conventions	55
PCI BIOS functions	55
Locating the Universe Chip	56
Read Configuration Byte	58
Read Configuration Dword	59
Read Configuration Word	58
Write Configuration Byte	59
Write Configuration Dword	60
Write Configuration Word	60
PCI bus, interrupt handling	54
PCI Ethernet controller, enabling	26
PCI local bus interface	2
pinouts	
auxiliary connector	18
interboard connector 1	21
interboard connector 2	22
keyboard port	17
mouse port	<i>See</i> auxiliary connector
P1 connector (XVME-973/1)	66
P2 connector (XVME-973/1)	67
P3 connector (XVME-973/1)	68
P4 connector (XVME-973/1)	69
P5 connector (XVME-973/1)	70
parallel port	16
serial ports	16
Universal Serial Bus (USB)	17
VGA	17
VMEbus (P1)	19
VMEbus (P2)	20
ports	
Abort/Clear CMOS	13
keyboard	5
LED/BIOS	14
mouse	4
NVRAM and DiskOnChip	15
parallel	4
serial	4
Universal Serial Bus (USB)	4
watchdog timer	14
ports, configuration of	38
power specifications	8
registers	
Abort/Clear CMOS port	13
LED/BIOS port	14
NVRAM and DiskOnChip	15
watchdog timer	14
reset options, VMEbus	54
RJ-45 10/100 Base-T Connector:	26
Security Menu, BIOS setup	41
serial port pinouts	16
serial ports	4, 16
shadow memory	34
shock specifications	7

specifications	
environmental.....	7
hardware.....	8
speed, CPU.....	8
SRAM, non-volatile.....	4
switch	
settings.....	12
switch location.....	10
system resources.....	43, 52
temperature specifications.....	7
Universal Serial Bus (USB) port.....	4, 17
Universe chip.....	51, 61, 62, 63, 64
USB.....	<i>See</i> Universal Serial Bus (USB)
VGA connector.....	17
vibration specifications.....	7
video controller.....	2
VME interface.....	51
VMEbus	
compliance	8
interface.....	3
interrupt handling.....	54
interrupt generation.....	54
master interface.....	52
reset options.....	54
slave interface.....	53
VMEbus connectors.....	19
VMEbus master interface.....	45
VMEbus slave interface.....	46
VMEbus system resources.....	43
watchdog timer.....	5
watchdog timer port.....	14
XVME-973/1.....	5, 9, 65
XVME-976.....	3, 9
XVME-977.....	5, 9
XVME-992.....	9

740653(D)

Xycom Automation, Inc.
750 North Maple Rd.
Saline, MI 48176
Phone: 734-429-4971
Fax: 734-429-1010

